

Medium & Heavy Payload Series

Hardware Installation Manual

Corresponding models: TM16 Series



This Manual contains information of the Techman Robot product series (hereinafter referred to as the TM Robot). The information contained herein is the property of Techman Robot Inc. (hereinafter referred to as the Corporation). No part of this publication may be reproduced or copied in any way, shape or form without prior authorization from the Corporation. No information contained herein shall be considered an offer or commitment. It may be subject to change without notice. This Manual will be reviewed periodically. The Corporation will not be liable for any error or omission.

TM logo is registered trademark of TECHMAN ROBOT INC. in Taiwan and other countries and the company reserves the ownership of this manual and its copy and its copyrights.

Revision History Table.....	8
1. Product Description.....	9
1.1 Product Description.....	9
1.2 How Can I Get Help?.....	9
1.3 Disposal and Environment.....	9
2. Safety Information.....	10
2.1 Overview.....	10
2.2 Warning and Caution Symbols.....	10
2.3 Safety Precautions.....	10
2.4 Validation and Liability.....	11
2.5 Limitations on Liability.....	11
2.6 General Safety Warning.....	11
2.7 Risk Assessment.....	12
2.8 Emergency Stop.....	12
2.9 Movement without Drive Power.....	12
2.10 Labels.....	14
3. Transportation and Storage.....	16
4. System Hardware.....	17
4.1 Overview.....	17
4.2 System Overview.....	17
4.2.1 Robot Arm.....	18
4.2.1.1 Dimension Drawings of Robot.....	18
4.2.1.2 Robot Assembly Diagram.....	19
4.2.1.3 Range of Motion.....	21
4.2.1.4 Robot Hazard Zone Diagram and Operator Position Diagram.....	23
4.2.1.5 Payload and Torque.....	24
4.2.1.6 Robot Arm Installation.....	25
4.2.2 Robot End Module.....	27
4.2.2.1 End Module Components.....	27
4.2.2.2 End Flange Surface.....	29
4.2.2.3 End Mounting Caution.....	30
4.2.2.4 End Indication Light Ring Table.....	30
4.2.3 Control Box.....	30
4.2.3.1 Robot Stick.....	31
4.2.4 Robot Light Module.....	33

4.2.4.1 Light Module Surface.....	33
4.2.4.2 Install Light Module.....	33
4.3 Operating Position of TM Robot with AGV/AIV	35
4.4 Working distance and field of view of TM Robot's EIH camera	35
5. Electrical Interface.....	37
5.1 Overview.....	37
5.2 Electrical Warnings and Cautions	37
5.3 Control Box	37
5.3.1 Safety Connector	39
5.3.1.1 Safety Input Connector	39
5.3.1.2 Safety Output Connector	41
5.3.2 Power Connector	43
5.3.3 Digital In/Out.....	43
5.3.3.1 Digital Input	43
5.3.3.2 Digital Output.....	45
5.3.4 Analog In	47
5.3.5 Analog Out.....	48
5.3.6 System Remote Power ON/OFF	48
5.3.7 EtherCAT: For EtherCAT Slave I/O Expansion.....	49
5.3.8 USB Port	49
5.4 Tool End I/O Interface.....	49
5.4.1 I/O Terminals.....	49
5.4.2 Connecting Tool End Digital Output.....	51
5.4.3 Connecting Tool End Digital Input.....	52
5.4.4 Connecting Tool End Analog Input.....	52
5.5 Control Box Interfaces.....	53
5.6 Control Box Power Interface and Robot Interface	55
5.6.1 Control Box Power Interface.....	55
5.6.2 Robot Interface	56
5.6.3 SEMI Emergency Off Interfaces (SEMI series exclusive).....	57
5.6.3.1 TM16M SEMI Series.....	57
5.6.4 Detachable I/O Panel	57
6. Unboxing & Installation.....	59
6.1 Overview.....	59
6.2 Inspecting the Equipment	59
6.2.1 Before Unpacking	59

6.2.2 Upon Unpacking	59
6.3 Unboxing.....	60
6.3.1 Carton Types	60
6.3.2 Contents of Each Carton	60
6.4 Installing Your Robot	63
6.4.1 Remove the Control Box	63
6.4.2 Verification Before Removal of the Robot Arm	64
6.4.3 Removal of the Robot Arm and Tightening	65
6.4.4 Connect the Robot and the Control Box	66
7. Maintenance and Repair	68
Appendix A. Technical Specifications.....	70

Tables

Table 1: Manual Title & Description.....	9
Table 2: Danger, Warning, and Caution Symbols	10
Table 3: Denotation of Labels	15
Table 4: Rated Torque and Limit for Repeated Peak Torque of Regular Payload Robot Series	25
Table 5: Robot Stick Basic Functions.....	32
Table 6: Robot Stick Advanced Functions	32
Table 7: Reference of the Symbol and Unit in Calculation the Torque Load of the Light Module.....	33
Table 8: Electrical Specification of the Light Module.....	34
Table 9: The Relation between the Working Distance and the Field of View	36
Table 10: Definitions of Safety Connectors	38
Table 11: Analog In & Analog Out	48
Table 12: 8-pin Digital I/O Connectors of Cable.....	50
Table 13: 8-pin Digital I/O Connector of Robot	50
Table 14: 5-pin Analog I/O Connector of Cable	51
Table 15: 5-pin Analog I/O connector of Robot.....	51
Table 16: Analog Input Range.....	52
Table 17: TM16 / TM16X Series Electrical Specifications	56
Table 18: TM16M Series Electrical Specifications	56
Table 19: The Robot Arm Carton Contents.....	61
Table 20: The Control Box Carton Contents.....	63
Table 21: Summary of the Preventive Maintenance Procedures and Guidelines	68
Table 22: Technical Specifications	70

Figures

Figure 1: References of Joints by Models	13
Figure 2: Reference of Brake Solenoid by Joints	14
Figure 3: Locations of Labels.....	15
Figure 4: System Overview	17
Figure 5: Dimension of TM16 / TM16M.....	18
Figure 6: Dimension of TM16X.....	19
Figure 7: Assembly of TM16 / TM16M	20
Figure 8: Assembly of TM16X.....	21
Figure 9: Side view of TM16 / TM16M / TM16X Movement Range Diagram.....	22
Figure 10: Pictorial view of TM16 / TM16M / TM16X Movement Range Diagram.....	23
Figure 11: Top View of TM16 / TM16M / TM16X Movement Range Diagram	23
Figure 12: Robot Hazard Zone Diagram and Operator Position Diagram of TM16 / TM16M / TM16X.....	24
Figure 13: Relationship between Payload and the Center of Gravity Offset in TM16 / TM16M / TM16X.....	25
Figure 14: Bottom View of Robot Base	26
Figure 15: Securing the ground wire with the robot.....	27
Figure 16: References of TM16 / TM16M End Module Components	27
Figure 17: References of TM16X End Module Components.....	28
Figure 18: References of End Flange Surface	29
Figure 19: The Exterior and Diagram of the Control Box.....	30
Figure 20: Securing the ground wire with control box.....	31
Figure 21: Robot Stick.....	31
Figure 22: Light Module Surface.....	33
Figure 23: Calculation the Torque Load of the Light Module.....	34
Figure 24: Electrical Polarity of Fill Light Cable	34
Figure 25: Top View of TM Robot Placed on the AGV/AIV.....	35
Figure 26: Working Distance and Field of View of TM Robot's EIH camera	36
Figure 27: Control Box I/O Configuration (1/2).....	37
Figure 28: Control Box I/O Configuration (2/2).....	38
Figure 29: Safety Input Connector	39
Figure 30: The Wiring Diagram Example of Switch Type Safety Device.	40
Figure 31: The Wiring Diagram Example of PNP Output Type Safety Device	40
Figure 32: The Wiring Diagram Example of PNP Output Type Safety Device	41
Figure 33: Safety Output Connector	42
Figure 34: Safety Output Connector Wiring Diagram	42
Figure 35: Power Connector.....	43

Figure 36: Digital Input	44
Figure 37: Set to Sink Input Type.....	44
Figure 38: Set to Source Input Type	45
Figure 39: Digital Output	45
Figure 40: Set to Sink Output Type.....	46
Figure 41: Set to Source Output Type.....	47
Figure 42: Analog In.....	47
Figure 43: Analog Out	48
Figure 44: System Remote Power ON/OFF	48
Figure 45: EtherCAT.....	49
Figure 46: Connecting Tool End Digital Output.....	51
Figure 47: Connecting Tool End Digital Input	52
Figure 48: Connecting Tool End Analog Input	52
Figure 49: Front View of the Control Box	53
Figure 50: Interfaces of the TM16 / TM16X Series	53
Figure 51: Interfaces of the TM16M Series	54
Figure 52: Interfaces of the TM16M SEMI Series.....	54
Figure 53: Control Box Power Interfaces	55
Figure 54: Robot Interface.....	56
Figure 55: The TM16M SEMI SEMI Emergency Off Interface.....	57
Figure 56: Detachable I/O Panel.....	58
Figure 57: Robot Arm Carton.....	60
Figure 58: Control Box Carton	60
Figure 59: Moving the Control Box (1/2)	64
Figure 60: Moving the Control Box (2/2)	64
Figure 61: Moving the Robot Arm (1/2).....	65
Figure 62: Moving the Robot Arm (2/2).....	65
Figure 63: Moving the SEMI Emergency OFF Box.....	66
Figure 64: Connecting the Robot and the Control Box	66
Figure 65: Air Filter Tray	69

Revision History Table

Revision	Date	Revised Content
01	June 2022	Original release

1. Product Description

1.1 Product Description

The TM Robot is a six-axis robot with power and force limiting function featuring simple programming, innovative integrated vision capabilities together with the latest safety functionality to run at full speed with barriers and operate in collaborative workspace.

1.2 How Can I Get Help?

You can access information sources on the corporate website:

<http://www.ia.omron.com/>

Related Manuals

This manual covers the hardware installation, operation and user maintenance of TM Robot. See the following table for additional available manuals.

Manual Title	Description
Safety Manual	Contains safety information for TM Robots.
TMflow	Instructions for use of TMflow software.
TMvision	Instructions for use of TMvision software.

Table 1: Manual Title & Description

1.3 Disposal and Environment

TM Robots must be disposed of in accordance with the applicable legislation, regulations, and codes by the authorities.

TM Robots are produced with restricted used of hazardous substances to protect the environment; as defined by the Europe RoHS directive 2011/65/EU. These substances include mercury, cadmium, lead, chromium VI, polybrominated biphenyls, and polybrominated diphenyl ethers.

The following symbols are affixed on the respective manuals to indicate conformity with the above legislation.



2. Safety Information

2.1 Overview

Users should read, understand and abide by the safety information provided in this manual before using the TM Robot.

2.2 Warning and Caution Symbols

The Table below shows the definitions of the warning and caution levels used in this manual. Pay close attention to them when reading the manual, and observe them to avoid personal injuries or equipment damage.



DANGER:

Identifies an imminently hazardous situation which, if not avoided, is likely to result in serious injury, and might result in death or severe property damage.



WARNING:

Identifies a potentially hazardous situation which, if not avoided, will result in minor or moderate injury, and might result in serious injury, death, or significant property damage.



CAUTION:

Identifies a potentially hazardous situation which, if not avoided, might result in minor injury, moderate injury, or property damage.

Table 2: Danger, Warning, and Caution Symbols

2.3 Safety Precautions



DANGER:

This product can cause serious injury or death, or damage to itself and other equipment, if the following safety precautions are not observed.

- All personnel who install, operate, teach, program, or maintain the system must read the *Hardware installation Manual*, *Software Manual*, and *Safety Manual* according to the software and hardware version of this product, and complete a training course for their responsibilities in regard to the robot.



Read Manual and Impact Warning Labels

- All personnel who design the robot system must read the *Hardware installation Manual*, *Software Manual*, and *Safety Manual* according to the software and hardware version of this product, and must comply with all local and national safety regulations for the location in which the robot is installed.
- The TM Robot must be used according to its intended use.

- Results of the risk assessment may require the use of additional risk reduction measures.
- Power to the robot and its power supply must be locked out and tagged out or have means to control hazardous energy or implement energy isolation before any maintenance is performed.
-  Dispose of the product in accordance with the relevant rules and regulations of the country or area where the product is used.

2.4 Validation and Liability

The information contained herein neither includes how to design, install, and operate a complete robotic arm system, nor involves the peripherals that may affect the safety of the complete system. The integrators of the robot should understand the safety laws and regulations in their countries and prevent hazards from occurring in the complete system.

This includes but is not limited to:

- Risk assessment of the whole system
- Adding other machines and additional risk reduction measures based on the results of the risk assessment
- Using appropriate software safety features
- Ensuring Users will not modify any safety measures
- Ensuring all systems are correctly designed and installed
- Clearly labeling user instructions
- Clearly marking the contact information for the integrator
- Making relevant documents accessible, including the risk assessment, and this manual



CAUTION:

This product is a partly complete machine. The design and installation of the complete system must comply with the safety standards and regulations in the country of use. Users and integrators of the robot should understand the safety laws and regulations in their countries and prevent major hazards from occurring in the complete system.

2.5 Limitations on Liability

Even if the safety instructions are followed, any safety information in the manual shall not be considered as a guarantee that the product will not cause any personal injury or property damage.

2.6 General Safety Warning

1. The noise measured in a factory setting is about 50.4 dB (A) without production. (Measured 1m from the robot and 1.6m above the floor, at 80% of maximum speed). If the sound pressure is over 80 dB(A) while operating, wear proper ear protection.
2. Environmental Conditions:

- Ambient air temperature: 0°C ~ +50°C
- Ambient relative humidity: < 85%
- Transportation & Storage condition: -20°C ~ +60°C
- Transportation & Storage humidity: < 75%
- The robot needs to be protected from shock or vibration
- Observe ESD precautions when installing or removing robot

2.7 Risk Assessment

Before installing or using this product, Users must first carry out the necessary risk assessment based on the conditions of use, and pay attention to the potential remaining risk addressed by the Corporation. Refer to and abide by the relevant chapters in *Safety Manual* in accordance with its software and hardware version.

2.8 Emergency Stop

If any accidents occur during the operation of the robot, Users can stop all movement by pressing the Emergency Stop switch. When the robot stops, Users must ensure that all hazards are eliminated before manually restarting the robot. The Emergency Stop switch is only for use in critical conditions. To stop the robot during normal operations use the Stop Button on the system controller. When Users presses the Emergency Stop switch, the TM Robot will disconnect power from the robot and activate the brakes after the robot motion is stopped. The indication light ring of the robot will not display light, and the three lights from the robot stick will be constantly blinking.

Once the risk assessment has been conducted, if an Emergency Stop switch needs to be installed, the selected device must comply with the requirements of IEC 60204-1. After an Emergency Stop, factory reset, or any other safety incident, refer and abide by the relevant chapters in *Safety Manual* in accordance with its software and hardware version.

2.9 Movement without Drive Power

Robot without Drive Power could be found in three circumstances: Emergency stop, when disengaging packaging posture to initial booting, and power loss. The first two could enter Safe Start up Mode by means of releasing the Emergency Switch; the latter one is when robot loses external power. Regarding how to operate as well as safety precautions refer and abide by the relevant chapters in the *Safety Manual*.

If the robot loses power, and joints need to be moved in order to clear error conditions, you will need to release the brake for each joint as follows:

1. Remove joint cover screws (M3, Torx-T10) and joint cover.

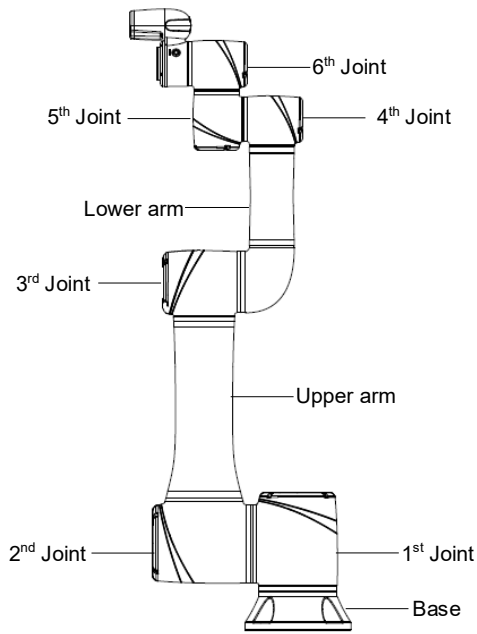

TM16 / TM16M

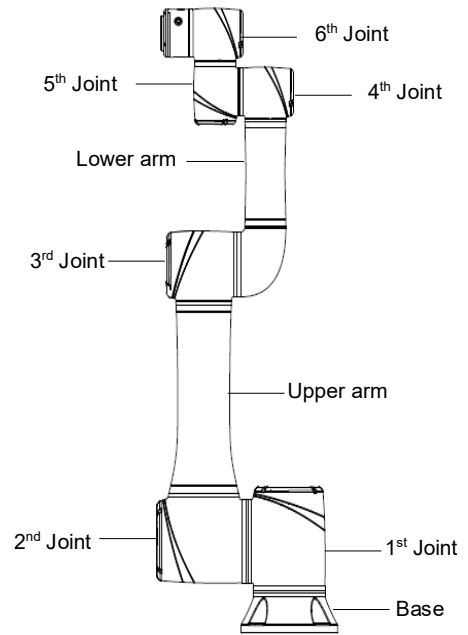

TM16X

Figure 1: References of Joints by Models

2. Release the brake by pushing the pin on the brake solenoid shown in the following figures.

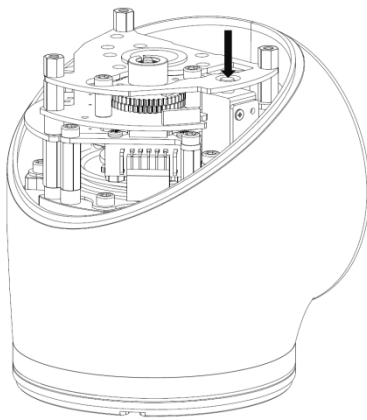

4th / 5th / 6th Joint

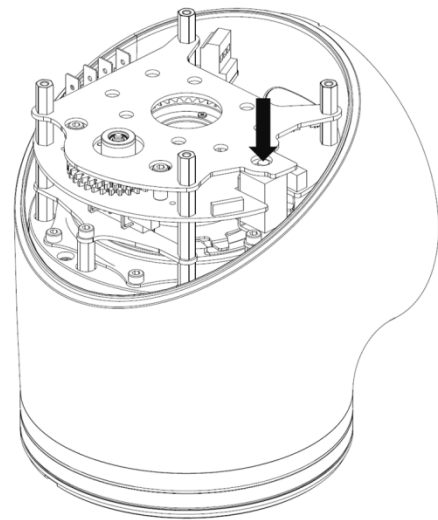

3rd Joint

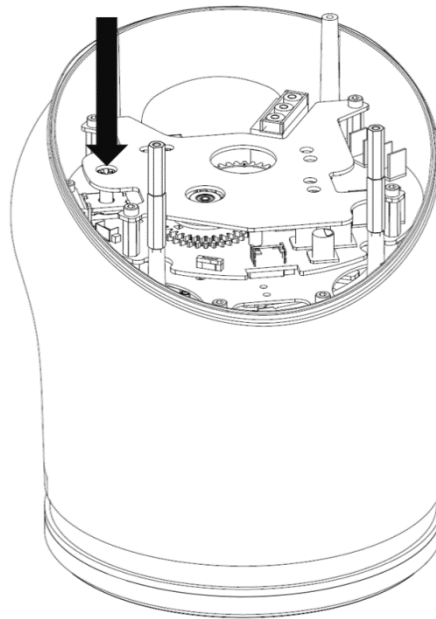

1st / 2nd Joint

Figure 2: Reference of Brake Solenoid by Joints





WARNING:

1. Due to gravity, additional supports are recommended when manually releasing the brake.
2. When manually moving each robot joint, the movement angle must be within a range of +/- 45°.

2.10 Labels

The following labels, especially the warning ones, are attached to the locations where specific dangers may occur. Be sure to comply with description and warnings of the labels when operating to avoid accidents. Do not tear, damage, or remove the labels. Be very careful if you need to handle the parts where the labels are attached.

A		Do not put your hand or fingers close to moving parts
B		Be careful not to be close to the moving parts and nearby areas to avoid impact
C		Do not touch any internal electric parts to avoid electric shock

D	<p>Distributed By: Omron Robotics and Safety Technologies, Inc. 4350 Norris Canyon Road, San Ramon, CA 94583</p> <p>Model: TMS-700 Controller</p> <p>P/N: ##### Rev. #</p> <p>S/N: XXXXXXXX</p> <p>Lot No: ##### HW: ## Weight: ## kg (## # lb)</p> <hr/> <p>Rated Voltage: 1Phase ##-##VAC Frequency: ##/## HZ Short Circuit Rating: ##A Full Load Current: ##A</p> <p>Manufactured by: Techman Robot Inc. 188 Wenhua 2nd Rd., Guishan Dist. Taoyuan City, 33383, Taiwan</p> <p>*S/N XXXXXXXX www.ia.omron.com</p>	Product label
---	---	---------------

Table 3: Denotation of Labels

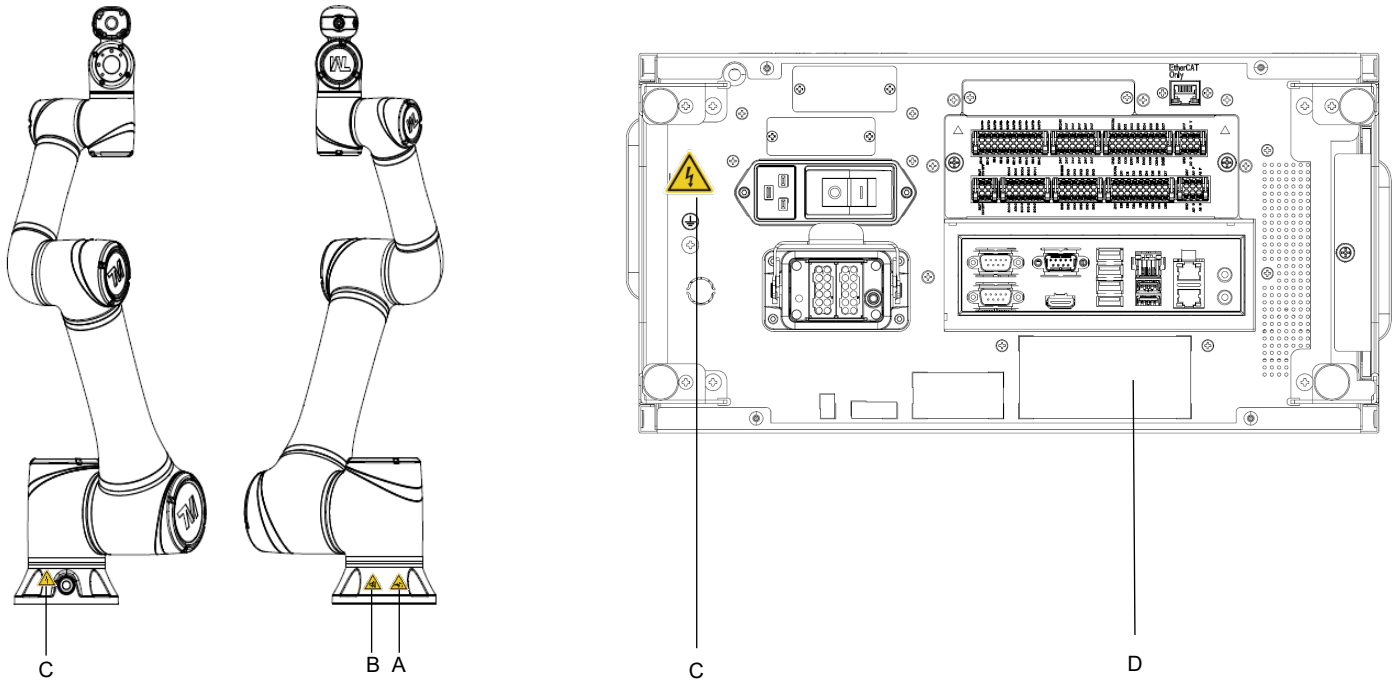

Figure 3: Locations of Labels

3. Transportation and Storage

Transport the TM Robot using its original packing materials. If you will need to transport the TM Robot after unpacking, store the packing materials in a dry place. Hold both arms of the TM Robot during transportation. Support the arms while tightening the base screws.

Lift the control box by its handles. Store the cables before transportation.



WARNING:

Pay attention to your posture when moving the arm and control box cartons to avoid back injury. The Corporation will not be liable for any injuries caused during transportation.



WARNING:

This product must be shipped and stored in a temperature-controlled environment, within the range -20°C to 60°C (-4°F to 140°F). The recommended humidity is up to 75 percent, non-condensing. It should be shipped and stored in the supplied package, which is designed to prevent damage from normal shock and vibration, You should protect the package from excessive shock and vibration.

The product must always be stored and shipped in an upright position in a clean, dry area that is free from condensation. Do not lay the package on its side or any other non-upright position. This could damage the product.

4. System Hardware

4.1 Overview

This chapter introduces the mechanical interface of the TM Robot System.

4.2 System Overview

TM Robot is made up of the robot arm and control box (including a robot stick).



Robot arm



Control Box



Robot Stick

4.2.1 Robot Arm

4.2.1.1 Dimension Drawings of Robot

Shown below is the dimension drawing of the robot

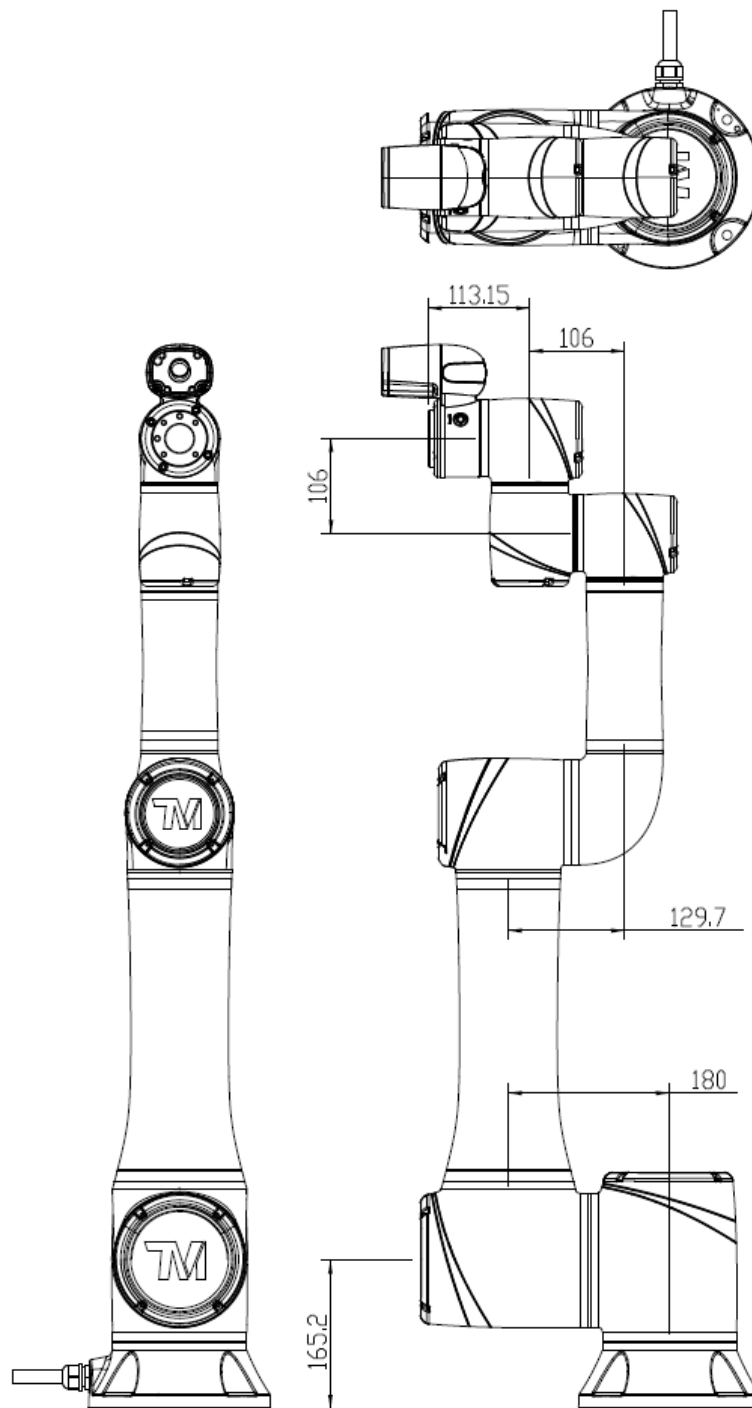

Figure 5: Dimension of TM16 / TM16M

*All measures are in mm.

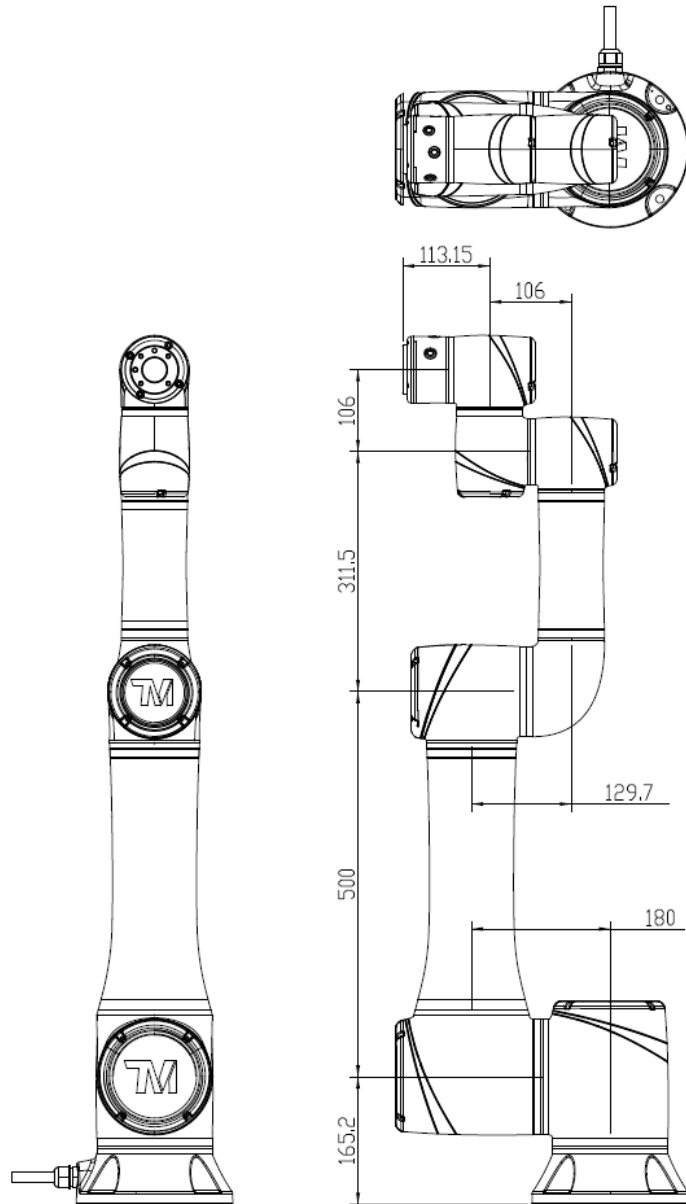

Figure 6: Dimension of TM16X

*All measures are in mm.

4.2.1.2 Robot Assembly Diagram

Shown below is an illustration of the robot components. To avoid safety risks, do not attempt to disassemble any component on your own. Contact your local corporation support for any service request.

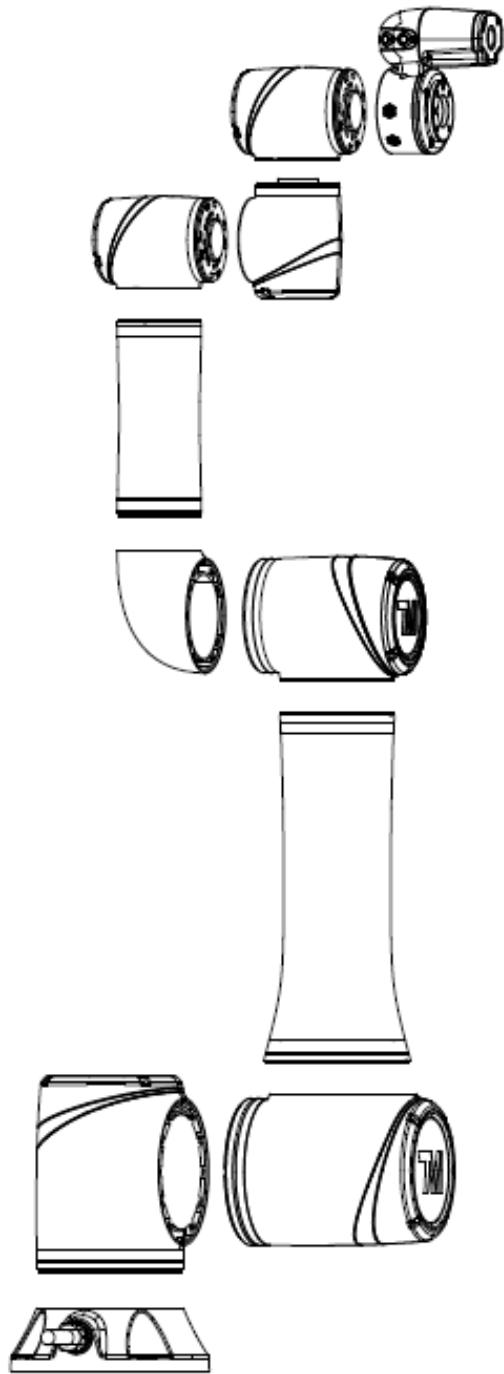

Figure 7: Assembly of TM16 / TM16M

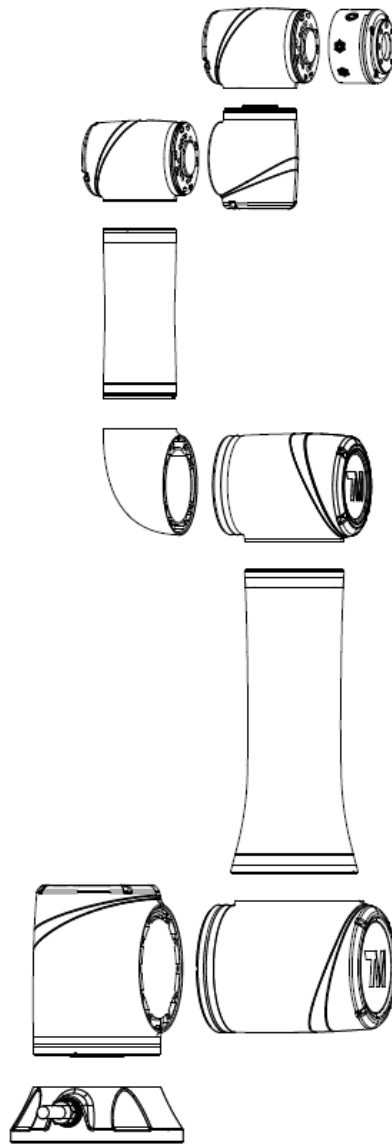

Figure 8: Assembly of TM16X

4.2.1.3 Range of Motion

The working spherical (radius) range from the base is 900 mm for the TM16 series.



DANGER:

With the exception of an individual being in full control of robot motion during hand-guiding, personnel shall be outside the safeguarded space when the robot is in motion while in manual mode (i.e. teaching).

The emergency stop on the robot stick must be readily accessible during manual mode. At least one emergency switch is installed outside of the motion range of the robot. When no motion limit is set for the robot, the motion range of the robot is equal to the maximum motion range of the robot arm. You can set a motion limit to avoid the situation whereby all operators have to be outside of the maximum motion range of the robot arm.

The robot stick should be placed in an area that the robot cannot reach. Users should also

make sure that the movement of the robot will not be within any area where personnel will enter to press any buttons on the robot stick.

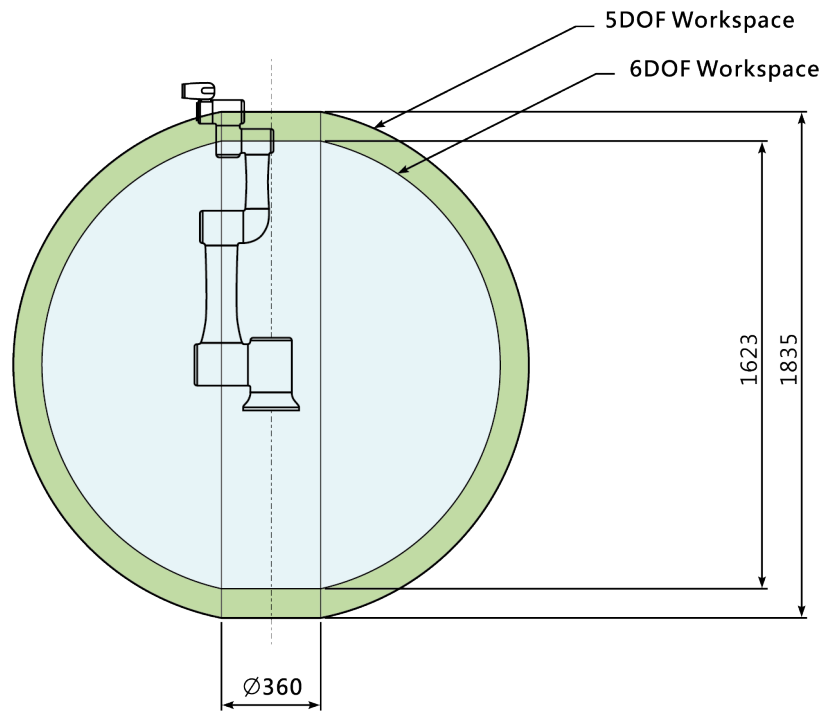

TM16 Workspace Side View

Figure 9: Side view of TM16 / TM16M / TM16X Movement Range Diagram

*All measures are in mm.

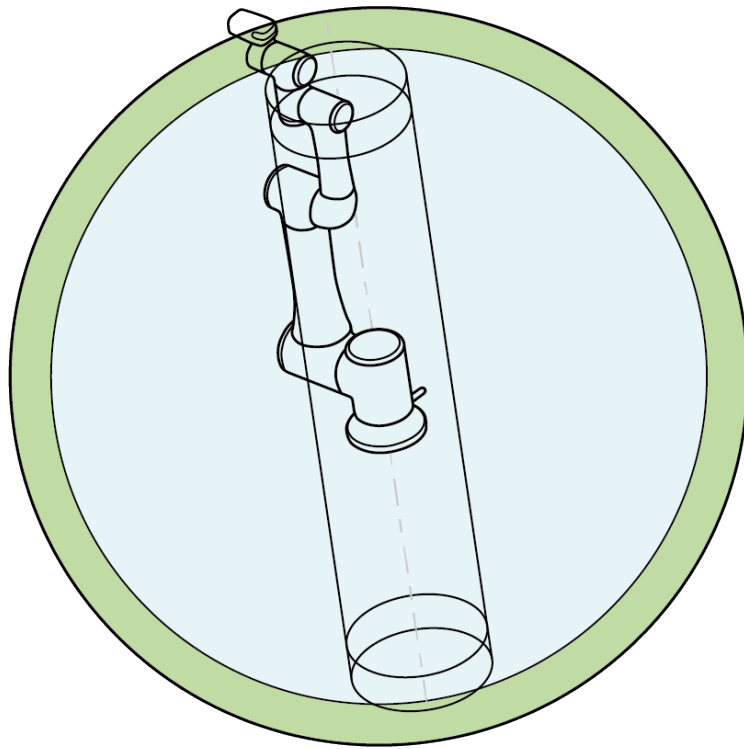
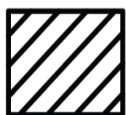
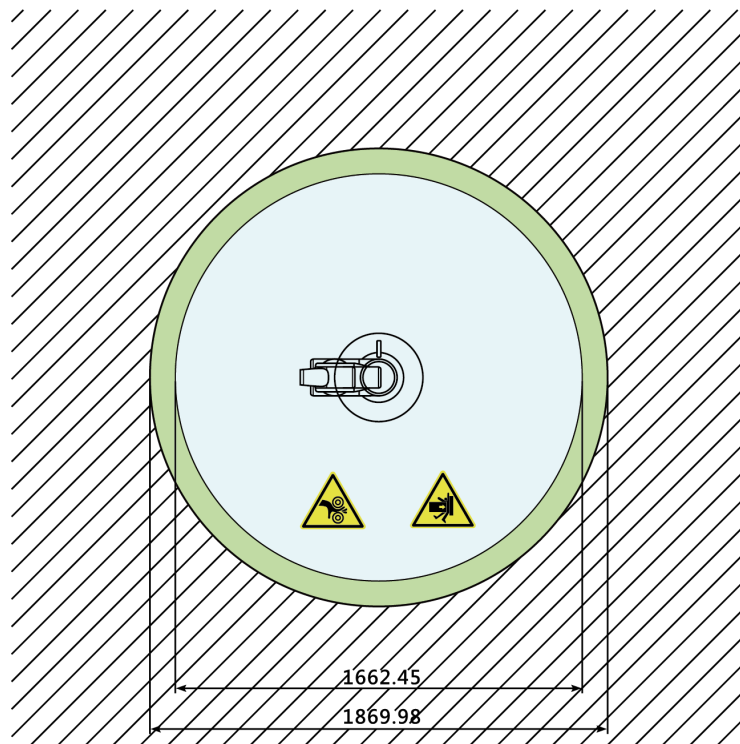

Figure 10: Pictorial view of TM16 / TM16M / TM16X Movement Range Diagram



Operator Position



Warning: Risk of crushing within the operating area of the arm.



Warning: Risk of collision within the operating area of the arm.

Figure 11: Top View of TM16 / TM16M / TM16X Movement Range Diagram

*All measures are in mm.

4.2.1.4 Robot Hazard Zone Diagram and Operator Position Diagram

Shown below is an illustration of the robot hazard zone and operator position diagrams. Do not operate the robot while anyone is inside of the hazard zone to avoid safety risks.

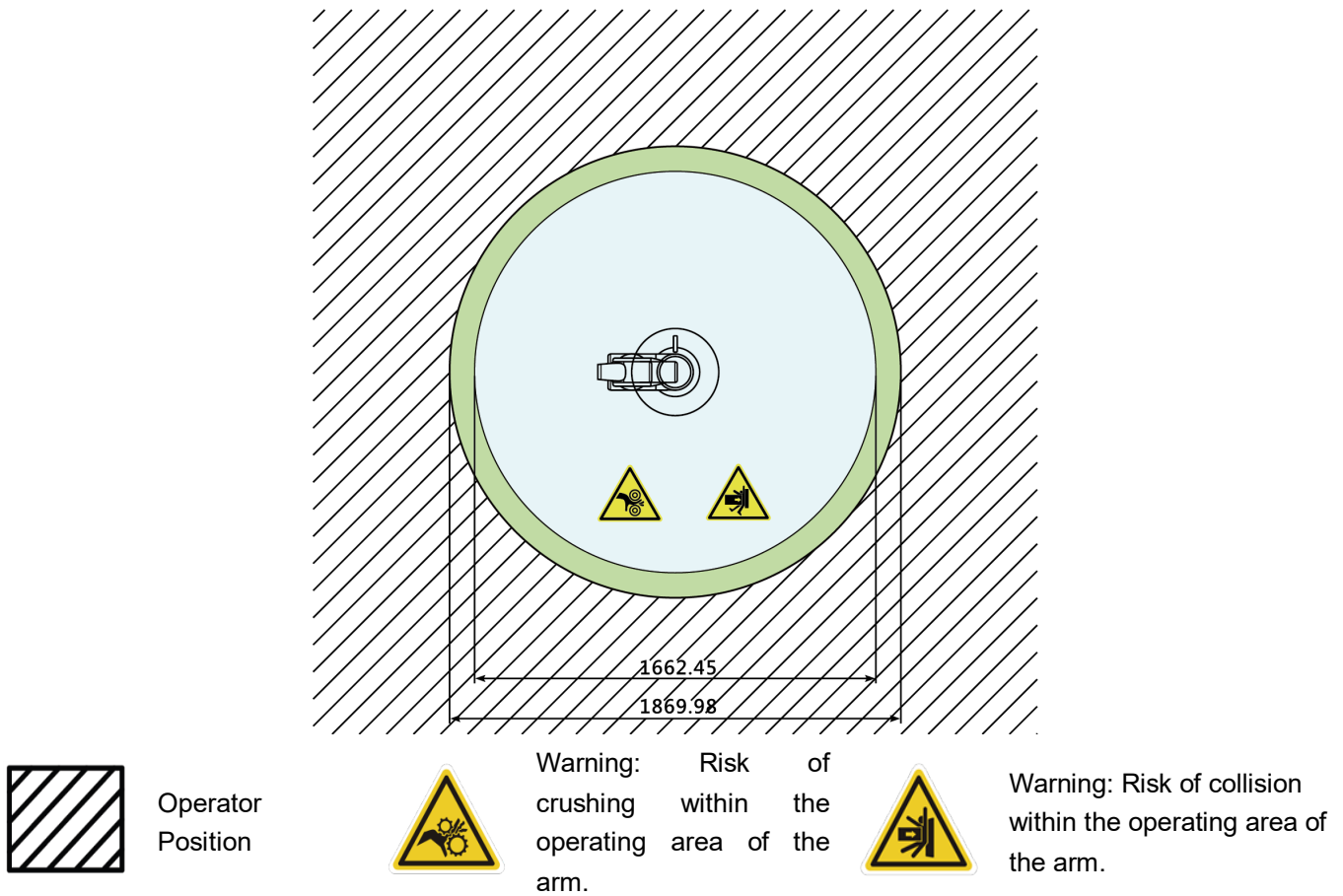

Figure 12: Robot Hazard Zone Diagram and Operator Position Diagram of TM16 / TM16M / TM16X

*All measures are in mm.

4.2.1.5 Payload and Torque

The maximum allowed payload of the robot arm is related to its center of gravity offset, which is defined as the distance from the center point of tool flange to the payload's center of gravity.

The following figure shows the relationship between payload and the center of gravity offset:

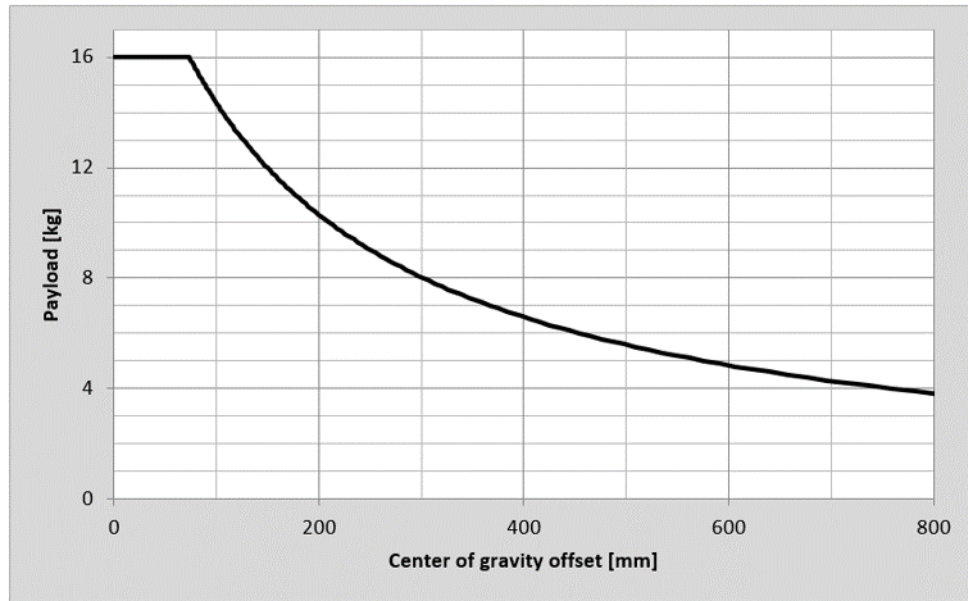

Figure 13: Relationship between Payload and the Center of Gravity Offset in TM16 / TM16M / TM16X

Refer the table below for the rated torque and the limit of repeated peak torque of the robot. Exceeding torque may reduce the life of the robot or damage the robot.

TM16 Series		
Model	Rated torque	Limit for repeated peak torque
J1	311	353
J2	311	353
J3	118	157
J4	41	54
J5	41	54
J6	34	54
Unit: Nm		

Table 4: Rated Torque and Limit for Repeated Peak Torque of Regular Payload Robot Series



WARNING:

Use the total weight of the end-effector and the payload to stay within the payload rating of the robot. Ensure that the system never exceeds that maximum payload. Users should perform a full risk assessment that includes the end-effector and payload samples to prevent hazards such as shocks, vibrations, collisions, entanglements, stabbings, and piercings to secure the entire system.

4.2.1.6 Robot Arm Installation

The robot can be secured to another surface with the use of (4) M10 screws and washers. The mounting pattern is shown below. The recommended tightening torque is 40 Nm.

Optional - Two openings for 6 mm position pins are provided for more secure position mounting.

Ensure the strength of the mounting surface and its surround area before installations for upside down mounting and side mounting such as on the ceiling or the wall. Wherever the installation takes place, the robot setting remains equivalent.

DANGER:

1. The TM Robot must be securely and tightly screwed down before use. The strength of the mounting surface must be sufficient.

When operating at high speed, the robot can generate up to 710 N reaction force to the mounting surface and screws. In order to avoid decreased performance caused by robot slip or vibration, the recommended mounting surface should be a steel plate at least 20 mm thick, its flatness should be 0.1 mm or less, its surface roughness should be Rz25 or less. The recommended screw should be M10 x L30 mm, at least 8.8 strength.

2. Do not immerse TM Robot in water. Installation in water or a humid environment will permanently damage the robot.



WARNING:

In contact with liquids with chemical substances such as chemical solvents, lubricants, sanitizers, cleansers, etc. may cause damage to the joint covers or other components of the robot.

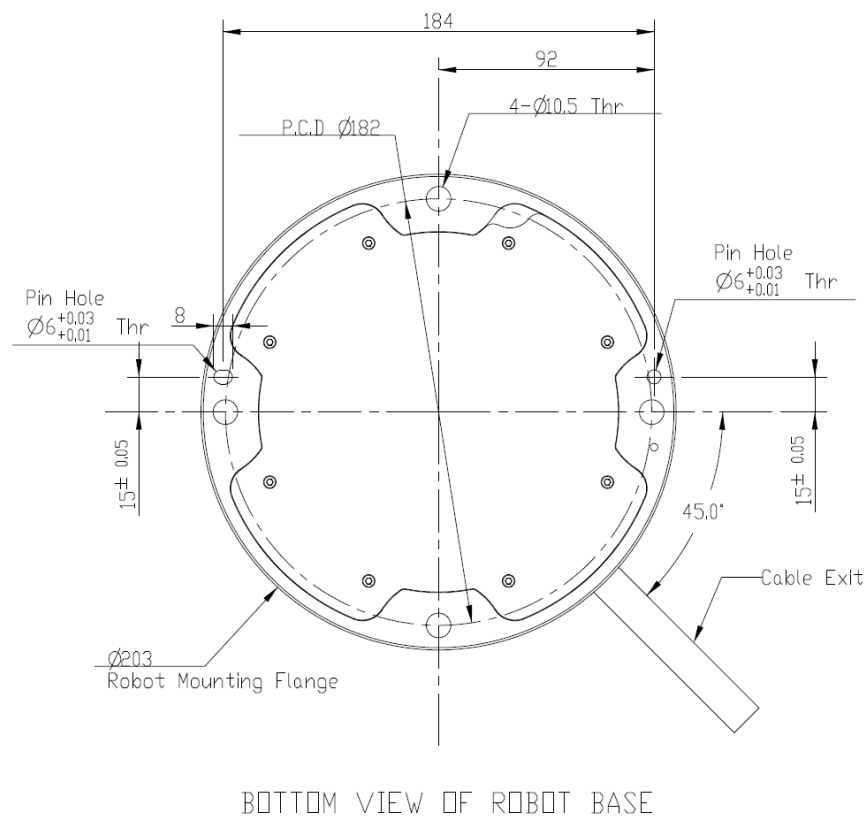

Figure 14: Bottom View of Robot Base

*All measures are in mm.

Use the M4L5 pan head screw to secure the ground wire with the robot as shown below.



Figure 15: Securing the ground wire with the robot

4.2.2 Robot End Module

4.2.2.1 End Module Components

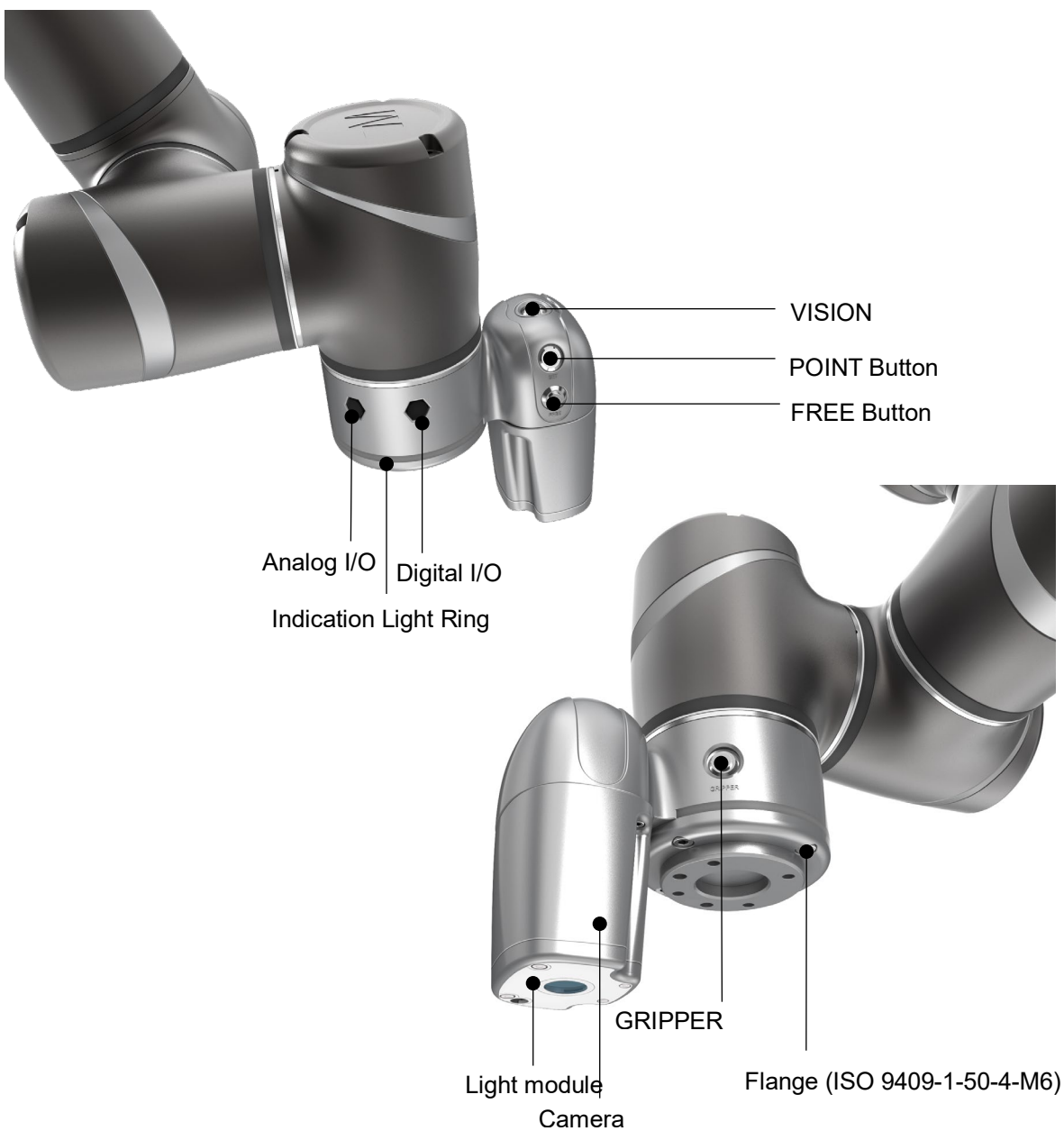

Figure 16: References of TM16 / TM16M End Module Components

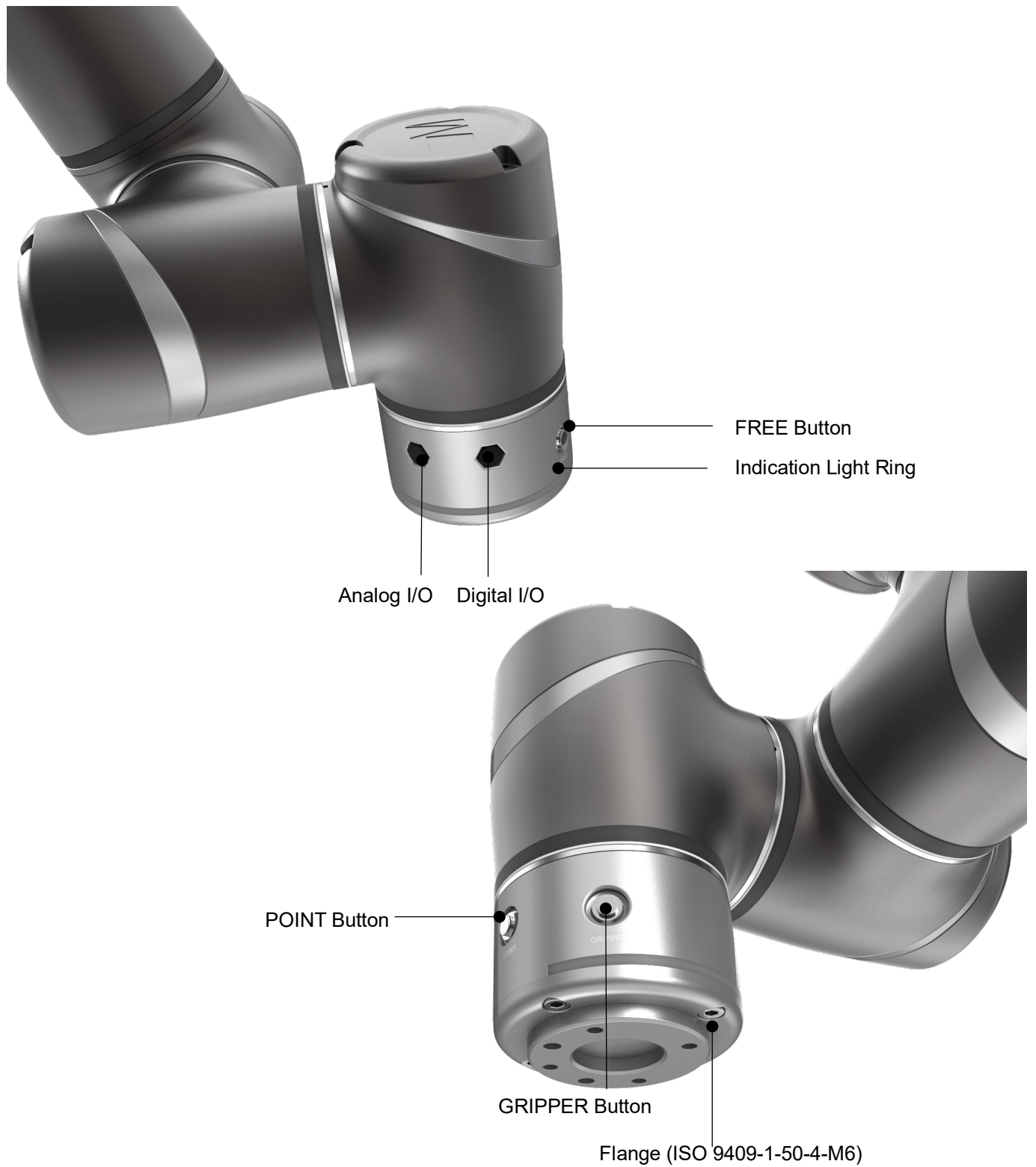

Figure 17: References of TM16X End Module Components

4.2.2.2 End Flange Surface

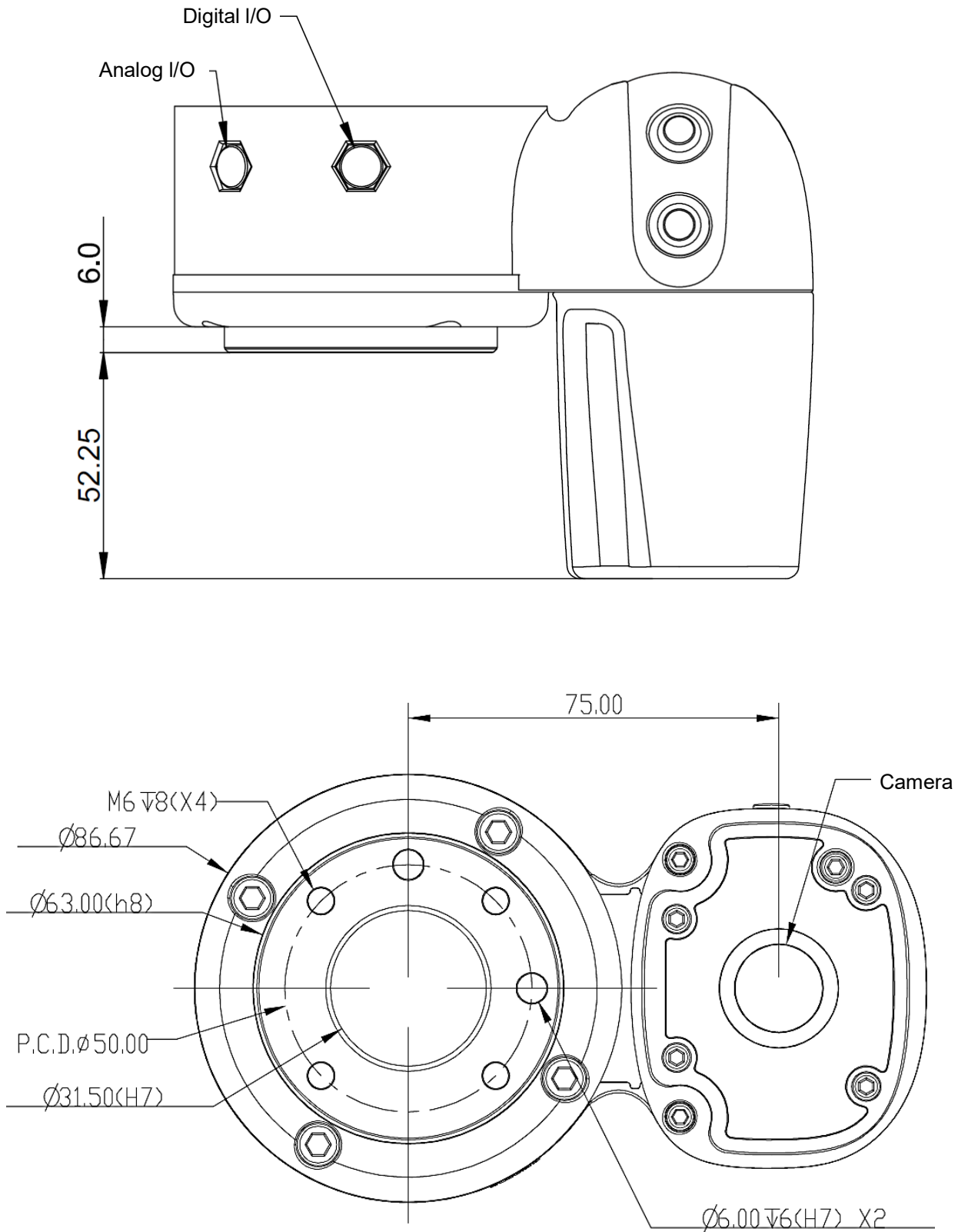

Figure 18: References of End Flange Surface

*All measures are in mm.

4.2.2.3 End Mounting Caution

The TM16 Series uses four M6 threaded holes on the end flange and four M6 screws for mounting tools. The strength of the M6 screw should be 8.8 or above, and the tightening torque of 9 Nm is recommended. If your application requires higher precision, you can use two positioning pins with a diameter of 6 mm for a more secure mounting.



DANGER:

1. Tools must be properly tightened when using this product. Improper tightening may cause the tool or part to fall out, or even cause personal injury and death.
2. Follow the rule $L \leq 8 + T$ to choose the screw to secure tools at the end of the flange, otherwise it may result in short circuits or irreparable damages at the bottom of the flange leading to the relevant parts replacement.

L	Length of the screw to secure tools. Unit: mm
8	Depth of the thread in the screw hole at the end of the flange. Unit: mm
T	Thickness of the object to be fixed. Unit: mm



CAUTION:

The application of mounting an actuator in the tool end with high vibration or impact may cause damage to the robot. Design the tool with proper anti-vibration/impact such as damping/cushion or shock absorber, or use low impact actuator such as pneumatic cylinder/system with shock absorb/buffer/cushion design to prevent this.

4.2.2.4 End Indication Light Ring Table

The Indication Light Ring of the TM Robot has several colors which represent different modes and error status. Refer to the Software Manual for the definition of the light colors.

4.2.3 Control Box

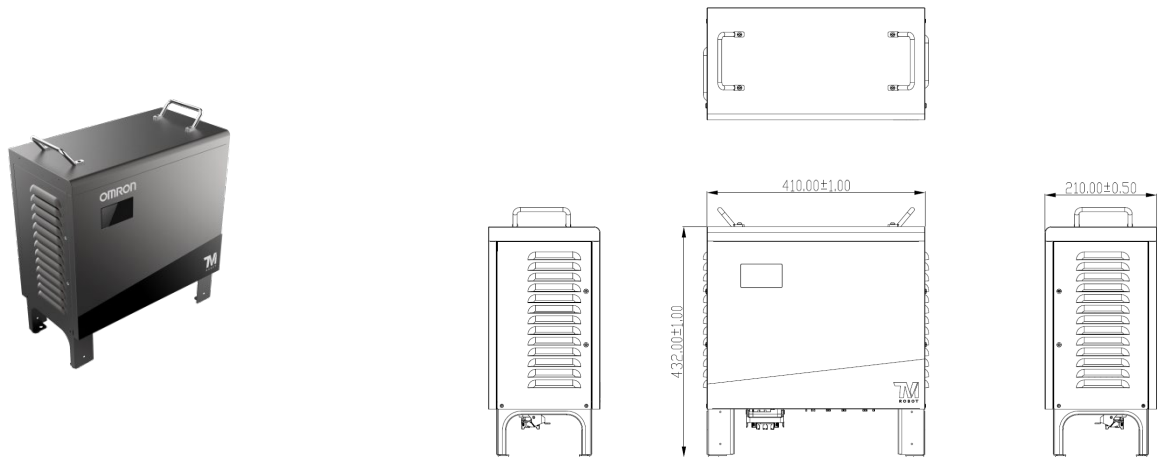

Figure 19: The Exterior and Diagram of the Control Box



CAUTION:

The control box can be placed on the floor or in your working cell. Note that 5 cm clearance should be left at both sides for ventilation.

Use the M4L6 screw to secure the ground wire with the control box as shown below.

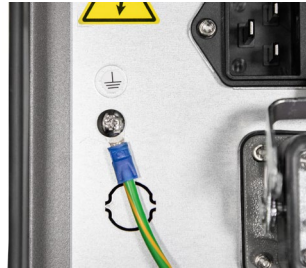

Figure 20: Securing the ground wire with control box

4.2.3.1 Robot Stick

The Robot Stick has 6 function buttons, 3 indicator lights, 1 Emergency Switch, 1 set of speed indicator, and 1 QR-code. Their functions are as follow:

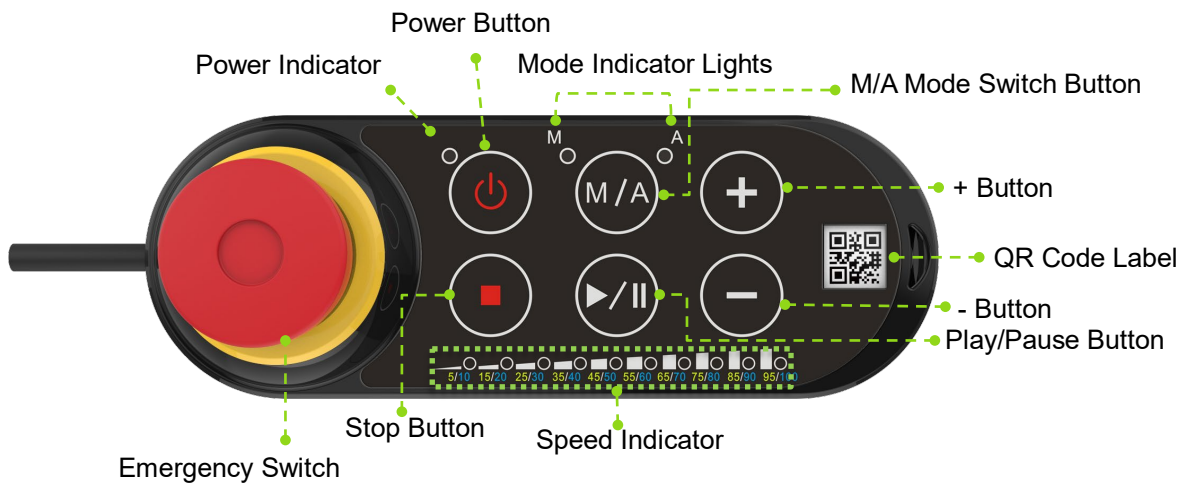

Figure 21: Robot Stick



CAUTION:

When operating the robot stick, do not use other objects than fingers to press the robot stick.

Items	Basic Function
Emergency Switch	Default emergency button for the robot
Power Button	Power initiation (single press)/ Shutdown (long press)
M/A Mode Switch Button	Toggle Manual/Auto Mode (single press). See <i>Safety Manual</i> for details.
Play/Pause Button	Play/Pause Project (single press)
Stop Button	Press this button to stop any project.

Items	Basic Function
+ - Button	Adjust project speed (single press) under Manual Trial Run Mode. See <i>Safety Manual</i> for details.
Power Indicator	This indicator shows the robot's power status. Not on: Switched off Flashing: Booting Constant: Startup completed
Mode Indicator Lights	One is Manual Mode, the other one is Auto Mode. They show the robot's current operating mode. Once boot up is complete only one will always be on.
Speed Indicator	Display the current project speed. Lit in green for 5% and in blue for 10% such as 4 in blue and 1 in green equals to 45%.
QR Code Label	The content of the SSID is also the robot's name in TCP/IP network.

Table 5: Robot Stick Basic Functions

Items	Advanced Function
Emergency Switch	- Press and release, and then wait for 3 seconds to enter Safe Start up Mode. - Press and release to enter Safe Start up Mode while booting.
Play/Pause Button	Play/pause visual calibration operation (single press)
Stop Button	Stop visual calibration operation (single press)
+ - Button	- Hold to jog the robot at the HMI robot controller page (Hold to Run). See <i>Safety Manual</i> for details. - Lock/ Unlock: press and hold both the + button and the - button until the mode indicator light flashes, then follow the sequence "-, +, -, -, +" to lock/unlock the Robot Stick (except the Power Button)

Table 6: Robot Stick Advanced Functions



CAUTION:

The robot stick is magnetic so that it can be attached to iron or steel surfaces. However, the risk of falling or rotating caused by poor attachment should be taken into account. It is recommended using the Robot Stick Stand (official accessory) to secure the robot stick. The Robot Stick Stand should be fixed with screws. Always attach the robot stick when it is not in use. The robot stick should be placed in a way such that the signal cables are routed to avoid damage caused by pulling.



DANGER:

1. The control box, cables, power signal cables, and robot stick cannot be used when any of them is in contact with liquids. This may result in personal injury or death.
2. The control box comes with the IP32 rating, but it is not recommended to use in dusty and humid environments. Pay extra attention to environments with conductive dust (such as metal particles).
3. Be noted that the control box can only be in standing pose for the IP32 rating.

4.2.4 Robot Light Module

4.2.4.1 Light Module Surface

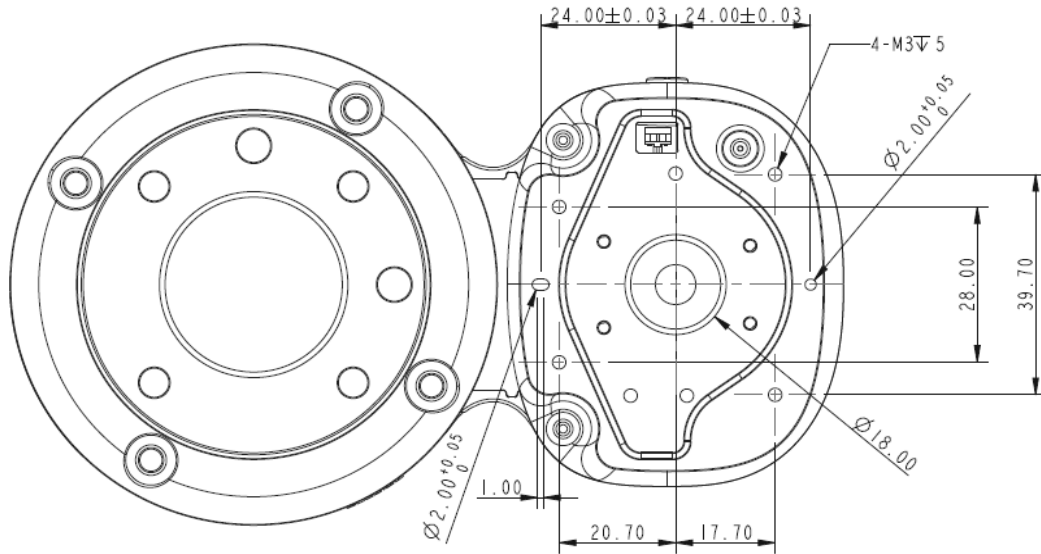

Figure 22: Light Module Surface

*All measures are in mm.

4.2.4.2 Install Light Module

The light module uses 4 of M3 screws to fix, and the recommended tightening torque is 1 Nm. For higher accuracy on usages in demand, use both of the 2 mm diameter openings with the positioning pins to get the better steadiness. Users can replace the light module by applications in demand. The choice depends on the torque load of the light module, the available load of the robot, the possible influence the other light module made to the camera's field of view, and the electrical specifications.

1. The torque load of the light module (M): this torque load must be lower than 900 kgfmm, which is the available strength of the camera module M3 screw can be loaded.

Calculation formula: $M = (L+59.2)*W$

The weight of the light module	W	kgf
The center of gravity of the light module	L	mm

Table 7: Reference of the Symbol and Unit in Calculation the Torque Load of the Light Module

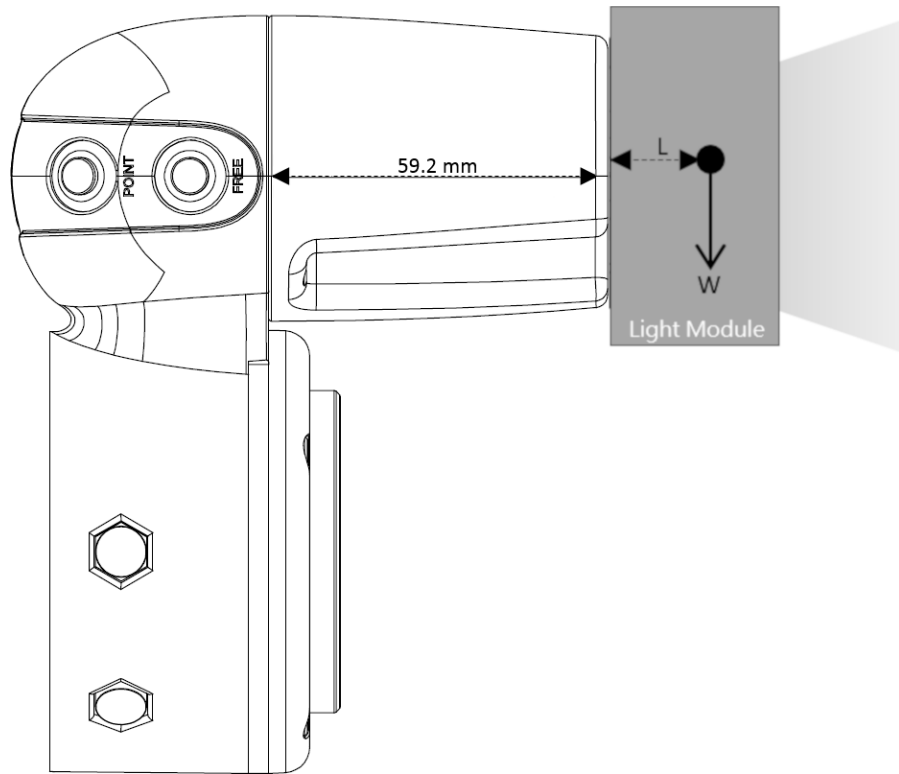

Figure 23: Calculation the Torque Load of the Light Module

2. The maximum allowed payload of the robot: the weight of the light module must match the relative relationship between the maximum allowed payload and the center of gravity offset distance. If the tool end flange goes with additional applications, it is required to generate the equivalent center of gravity for its position and total load from the combination of the light module and the application tool as well as follow 4.2.1.5 Payload and Torque of this manual.
3. Refer to 4.4 for Working distance and field of view of TM Robot's EIH camera.
4. Electrical Specification of the Light Module

Voltage:	24V	Current:	< 900mA
The total current of the tool end and the light module has to be lower than 1.5A.			

Table 8: Electrical Specification of the Light Module

Fill light cable:

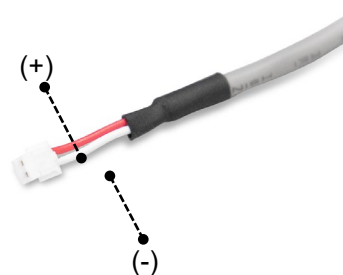

Figure 24: Electrical Polarity of Fill Light Cable

Connector: 2P/1.5 mm pin pitch. Refer to JST model ZHR-4 series.

Dimming mode: PWM control



NOTE:

The robot comes with the IP54 rating, but the Corporation does not guarantee this rating if users replace with the other light modules.



DANGER:

Be aware that the tool must be correctly and firmly secured to use with this product; otherwise, personal injuries or death may occur should the tool or the workpiece fall.

4.3 Operating Position of TM Robot with AGV/AIV

When TM Robot is placed on an AGV/AIV in operation, the TM Robot should be paused and should not exceed the footprint of the AGV/AIV.

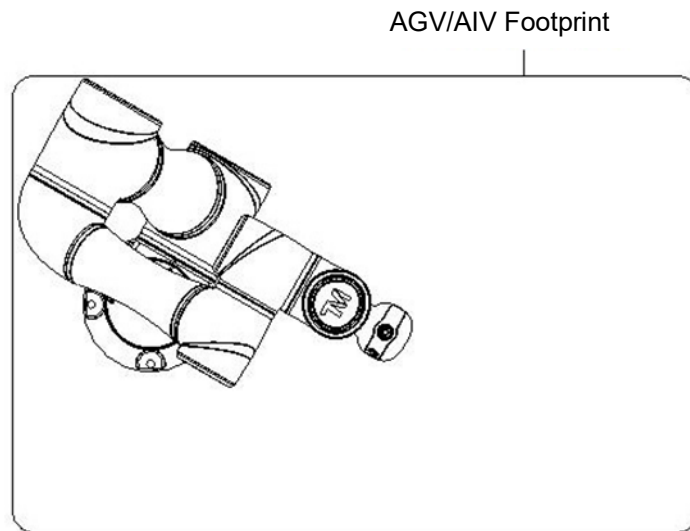

Figure 25: Top View of TM Robot Placed on the AGV/AIV

4.4 Working distance and field of view of TM Robot's EIH camera

The field of view of TM Robot's EIH camera varies linearly in accordance with the working distance. The minimum working distance is about 100 mm and the maximum working distance is about 300 mm. The zero working distance point is approximately 46.5 mm in front of the flange surface and right behind the center of the protection lens.

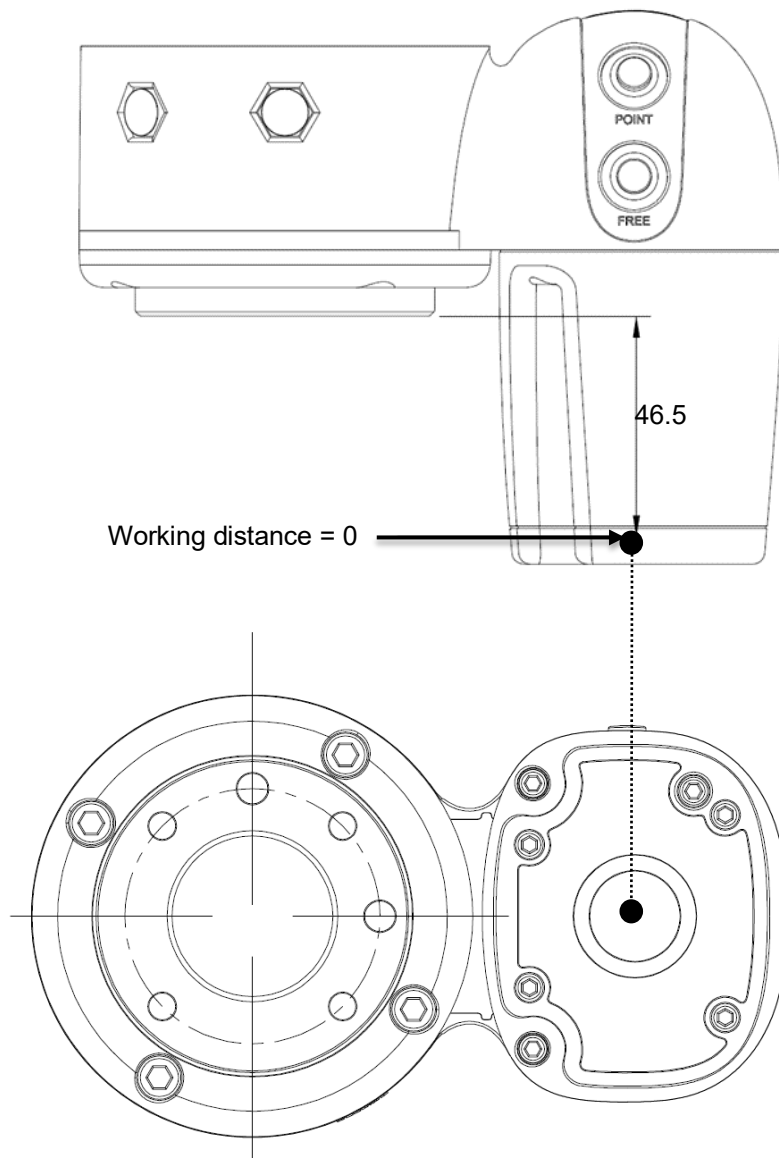

Figure 26: Working Distance and Field of View of TM Robot's EIH camera

*All measures are in mm.

The relation between the working distance and the field of view is listed below.

Working distance (mm)	300	100
Field of view (mm)		
Width	281.6	96.9
Height	211.2	72.7

Table 9: The Relation between the Working Distance and the Field of View

5. Electrical Interface

5.1 Overview

This chapter introduces all electrical interfaces of the robot arm and control box.

5.2 Electrical Warnings and Cautions

The application design and installation of the robot should comply with the following warnings.



DANGER:

1. Ensure all pieces of the equipment are kept dry. If water enters the equipment, disconnect the power and contact your supplier.
2. Only use the original cables included with the robot. If you need longer cables, contact your supplier.
3. Ensure that the robot is properly grounded. If the grounding is not correct, it may cause a fire or electric shock.



WARNING:

The I/O cables used for the link between the control box and other pieces of equipment should not be longer than 30 meters, unless testing shows that longer cables are feasible.

5.3 Control Box



WARNING:

Except for USB ports, other interfaces have to be installed while arm is powered off. Do not install while arm is on to avoid abnormal shutdown.

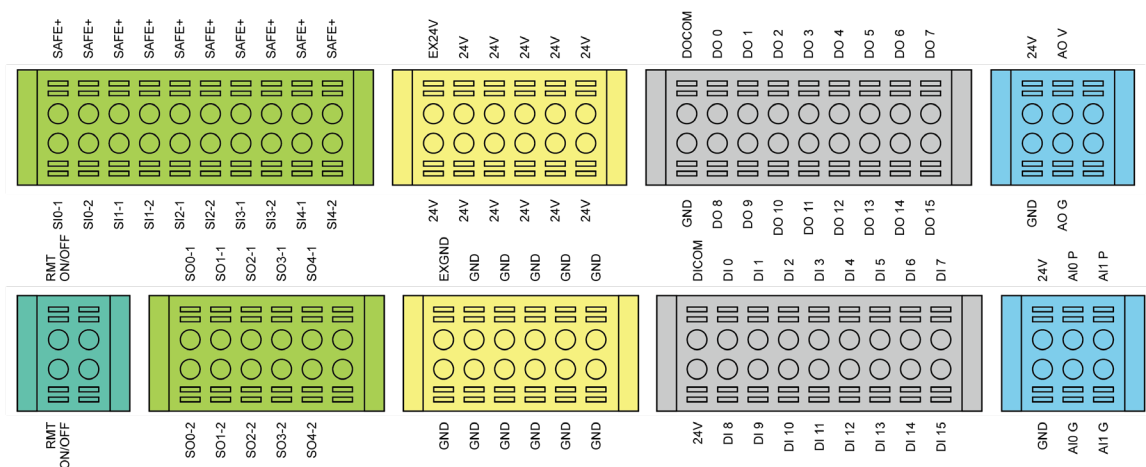

Figure 27: Control Box I/O Configuration (1/2)

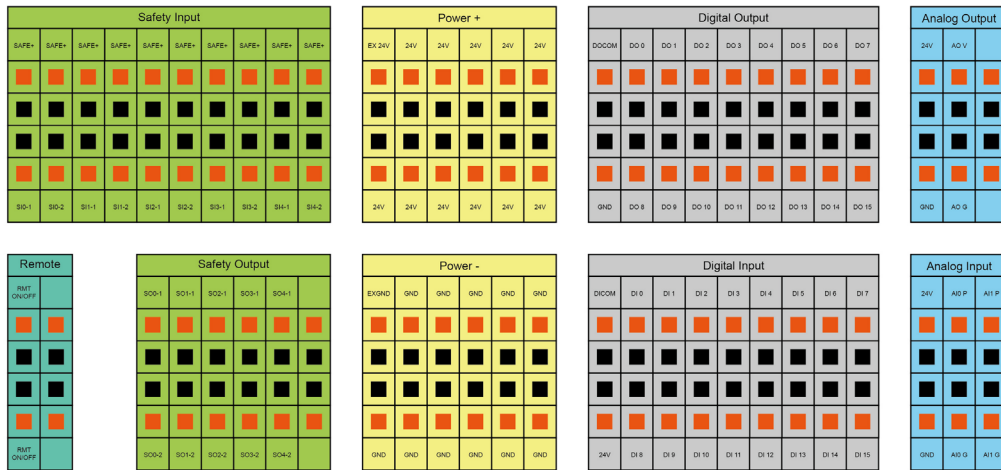

Figure 28: Control Box I/O Configuration (2/2)

Input		Output			
Safety Connector	Definition	SF Input	Safety Connector	Definition	SF Output
SI0-1 SI0-2	User Connected ESTOP Input	SF1	SO0-1 SO0-2	Robot ESTOP Output	SF10
SI1-1 SI1-2	User Connected External Safeguard Input	SF3	SO1-1 SO1-2	User Connected External Safeguard Output	SF11
SI2-1 SI2-2	User Connected External Safeguard Input for Human– Machine Safety Settings	SF9	SO2-1 SO2-2	User Connected External Safeguard Output for Human– Machine Safety Settings	SF12
SI3-1 SI3-2	User Connected Enabling Device Input	SF15	SO3-1 SO3-2	Robot Internal Protective Stop Output	SF13
SI4-1 SI4-2	User Connected ESTOP Input without Robot ESTOP Output	SF16	SO4-1 SO4-2	Robot Encoder Standstill Output	SF14

Table 10: Definitions of Safety Connectors

Note

NOTE:

For details about safety functions, please refer to the *Safety Manual*.

5.3.1 Safety Connector

Safety I/O comes with dual redundant channel connector and has to keep both channel input/output the same value simultaneously. Single fault on either one of the single channel will not result in failure of safety functions.

5.3.1.1 Safety Input Connector

1. User Connected ESTOP Input Port is a N.C. contact (Normally closed). When User Connected ESTOP Input Port is OPEN, the robot enters the Emergency STOP state.
2. User Connected External Safeguard Input Port is a N.C. contact (Normally closed). When User Connected External Safeguard Input Port is OPEN, the robot enters the Protective Stop state.
3. User Connected External Safeguard Input Port for Human–Machine Safety Settings is a N.C. contact (Normally closed). When User Connected External Safeguard Input Port for Human–Machine Safety Settings is OPEN, the robot decrease the limits to which is set in Human-Machine Safety Settings
4. User Connected Enabling Device Input Port is an N.C. contact (Normally closed). When User Connected Enabling Device Input Port is OPEN in Manual mode, the robot is unable to present manual control operation. When User Connected Enabling Device Input Port is CLOSED in Manual mode, the robot is able to present manual control operation.
5. User Connected ESTOP Input Port without Robot ESTOP Output functions as the User Connected ESTOP Input Port above, but it does not trigger the function of Robot ESTOP output.

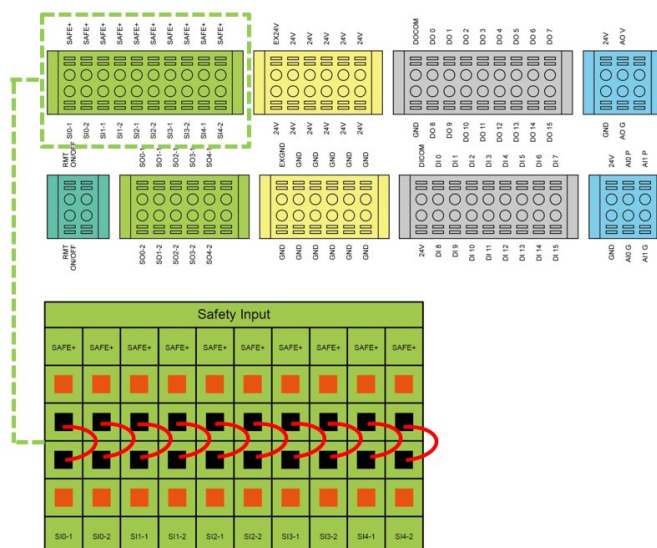

Figure 29: Safety Input Connector

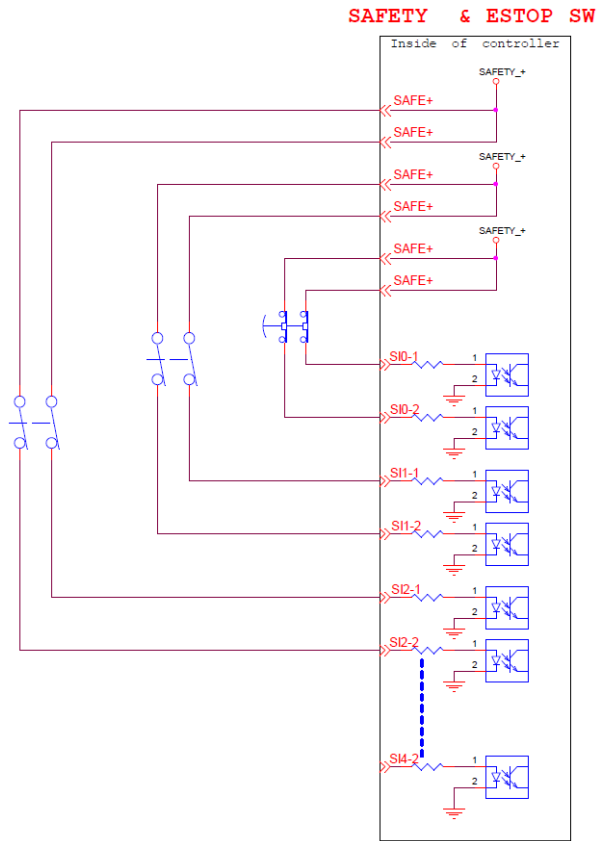

Figure 30: The Wiring Diagram Example of Switch Type Safety Device.

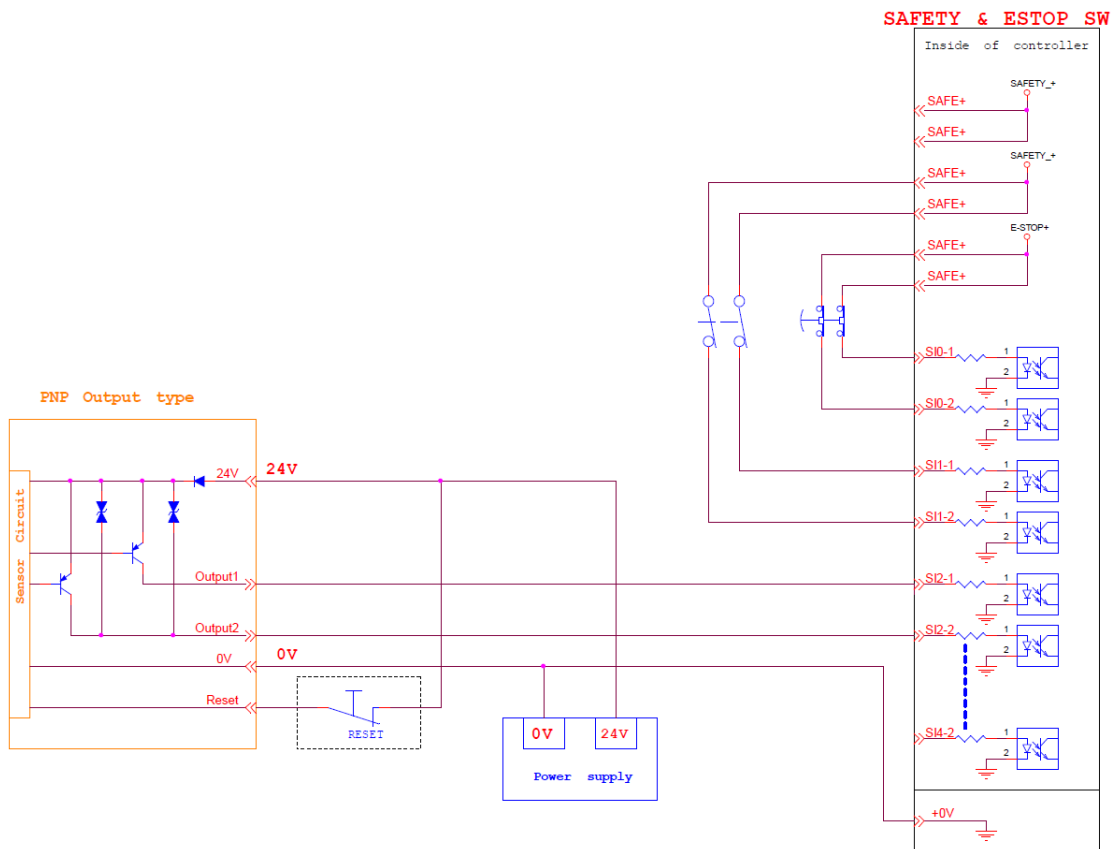

Figure 31: The Wiring Diagram Example of PNP Output Type Safety Device

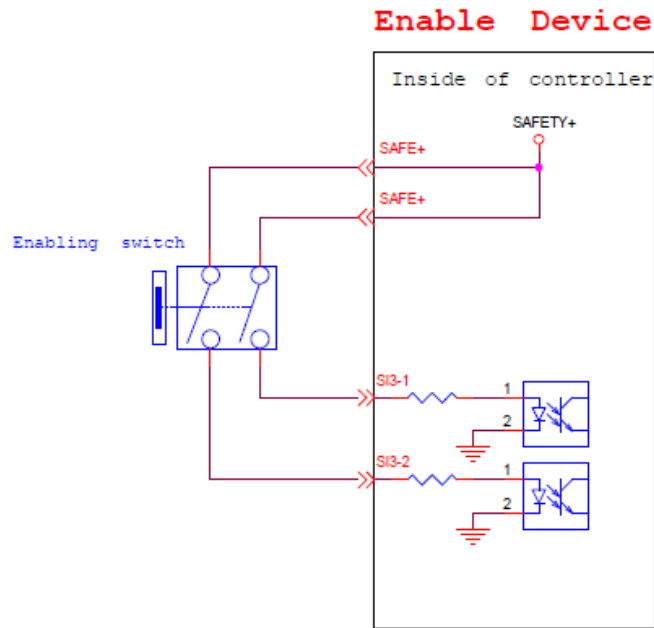

Figure 32: The Wiring Diagram Example of PNP Output Type Safety Device

5.3.1.2 Safety Output Connector

1. Robot ESTOP Output Port. When the robot triggers the Robot (stick) Emergency Stop signal, the output will be LOW.
2. User Connected External Safeguard Output Port. When the robot triggers the User Connected External Safeguard Input, the output will be LOW.
3. User Connected External Safeguard Output Port for Human–Machine Safety Settings. When the robot triggers the User Connected External Safeguard Input for Human–Machine Safety Settings, the output will be LOW.
4. Robot Internal Protective Stop Output Port. When the robot triggers the internal Protective Stop, the output will be LOW.
5. Robot Encoder Standstill Output Port. When the Encoder Standstill is not monitoring (robot is moving), the output will be LOW.

For details about the safety functions, please refer to the *Safety Manual*.

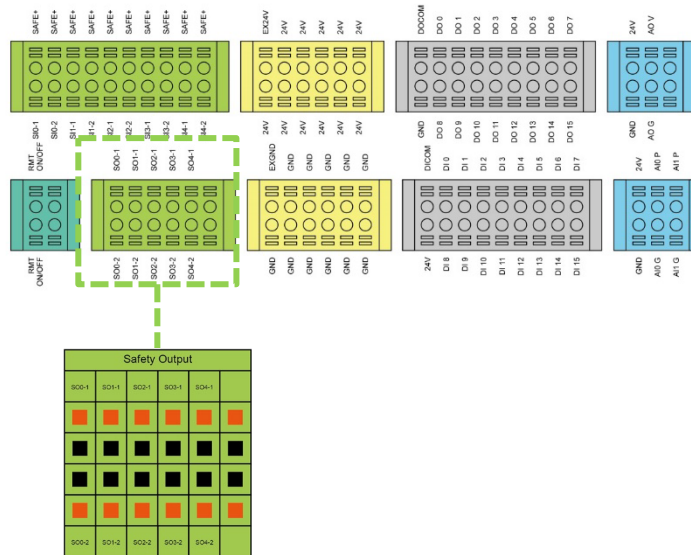

Figure 33: Safety Output Connector

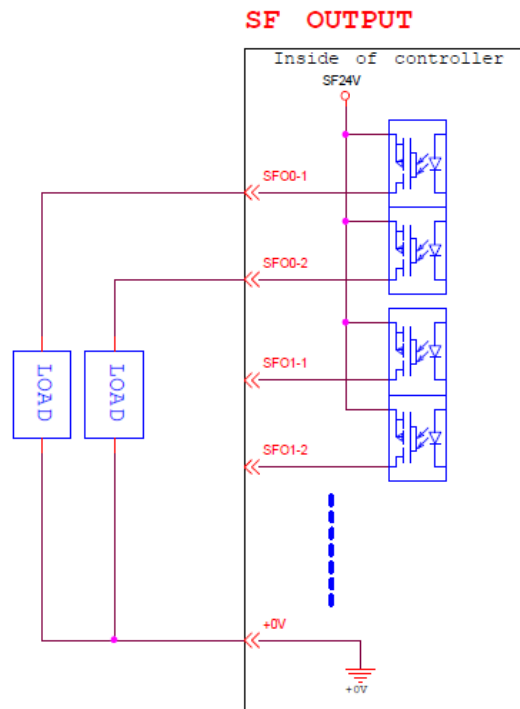

Figure 34: Safety Output Connector Wiring Diagram



DANGER:

1. Do not connect the safety signals to a non-safety device without the fulfilled safety level. Failure to do so may result in injury or death due to a malfunction of the safety stop.
2. All safety I/Os come with dual redundant channel connectors. Maintain both redundant channels while pairing and connecting to make sure that single fault on either one of the single channel will not result in failure of safety functions.
3. Before putting to use the robot, be sure to check the safety functions and schedule to check the safety functions for a regular basis.

5.3.2 Power Connector

1. During boot, the control box will check for an external 24V input. If none is found, then it will switch to the internal 24V supply.
2. The control box itself offers a 24V/2A output (24_EX). If the 24V load exceeds 2A, it enters Safe Mode and disables the 24V output.
3. EX24V provides an external 24V input port. If the load exceeds 2A an external power supply can be used instead. The load on EX24V must not exceed 3.5A.

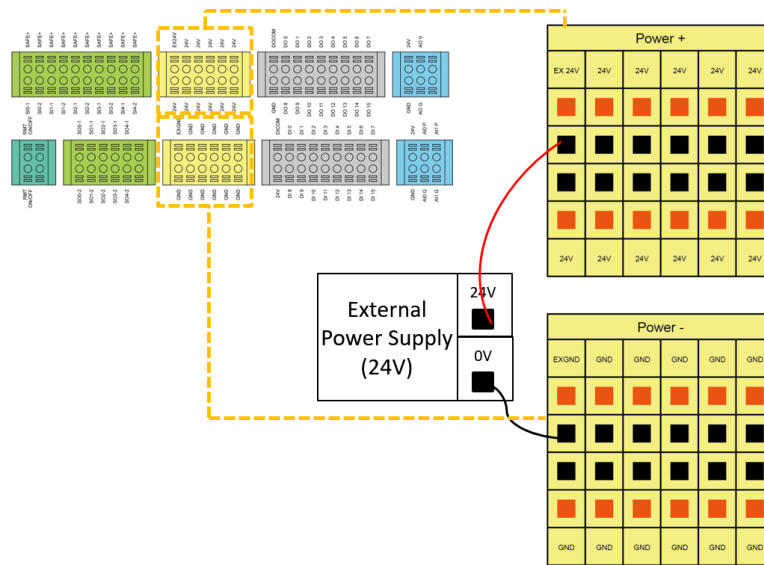

Figure 35: Power Connector

5.3.3 Digital In/Out

Digital input/output each has 16 channels, and its application is connected to the following sections.

5.3.3.1 Digital Input

Inputs can be set to either sink input or source input by selection.

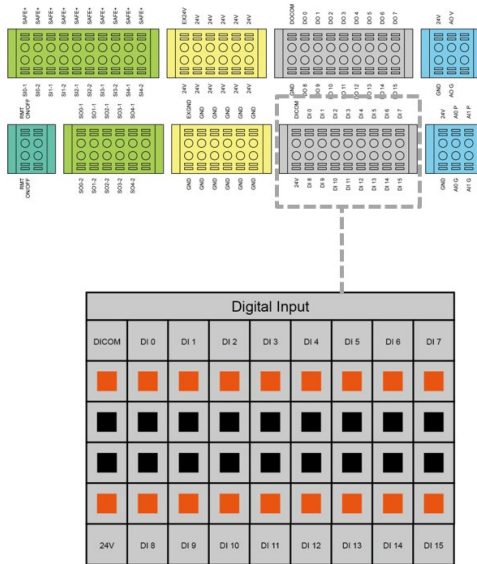

Figure 36: Digital Input

- Set to sink input type

When a device such as a transistor output sensor is connected, NPN open collector transistor output can be used.

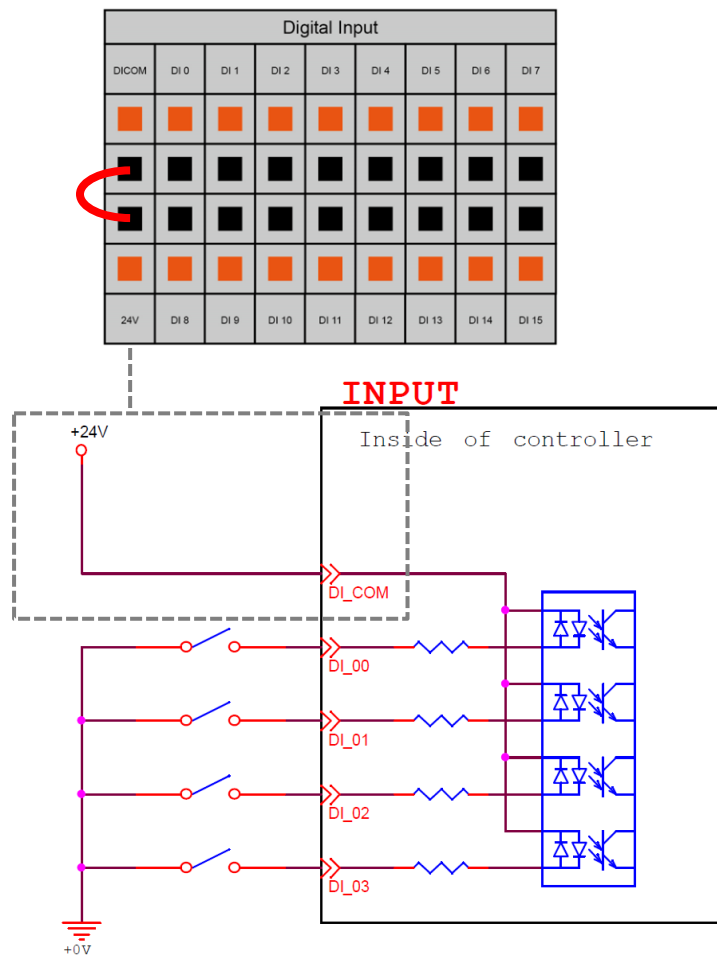

Figure 37: Set to Sink Input Type

- Set to Source input type

When a device such as a transistor output sensor is connected, PNP open collector transistor output can be used.

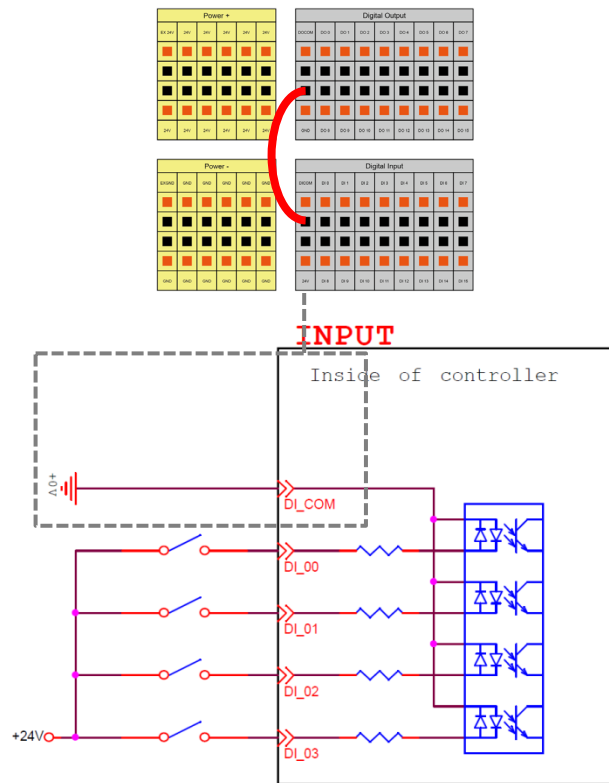

Figure 38: Set to Source Input Type

5.3.3.2 Digital Output

Outputs can be set to either sink output or source output by selection.

The maximum drive current is 300mA per channel. If the load exceeds 300mA, a relay should be used to drive it.

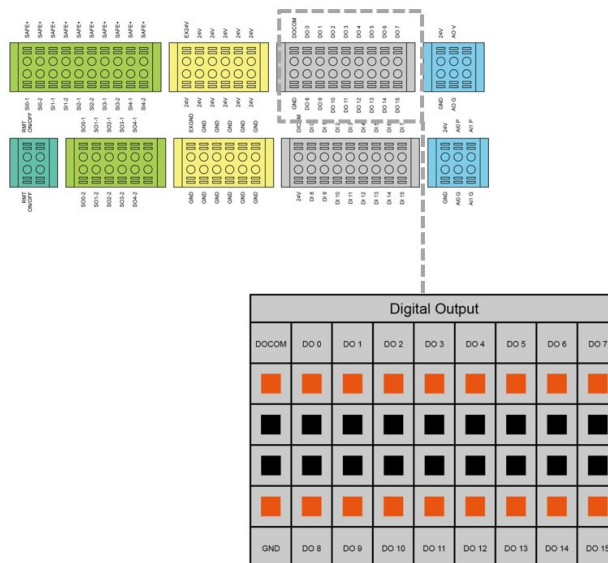

Figure 39: Digital Output

- Set to sink output type

Connect DO_COM terminal to the minus side of the power supply.

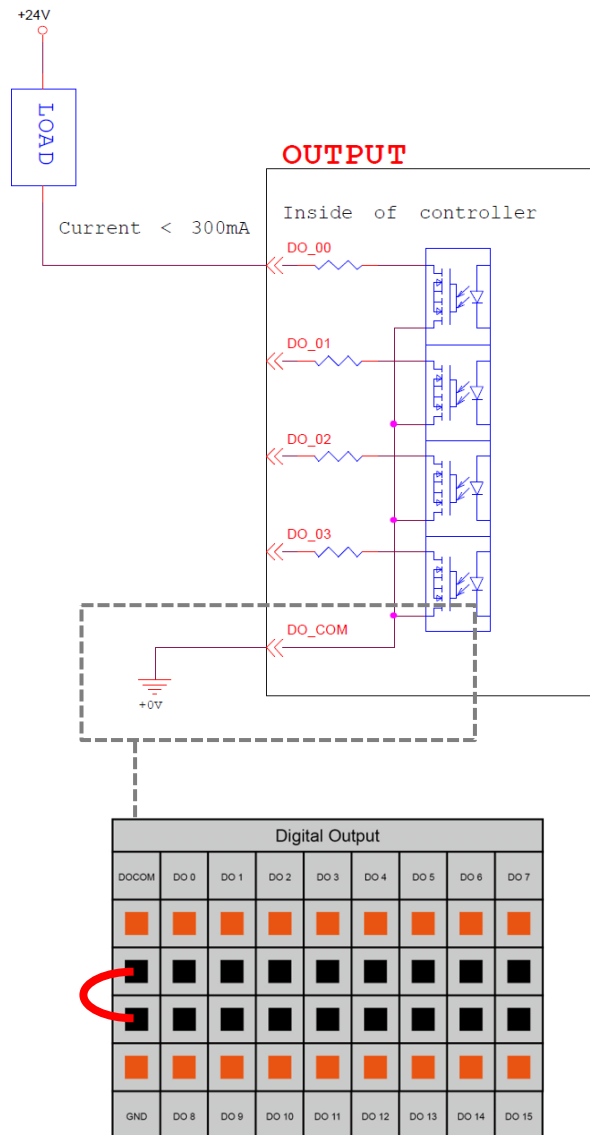

Figure 40: Set to Sink Output Type

- Set to source output type

Connect DO_COM terminal to the plus side of the power supply.

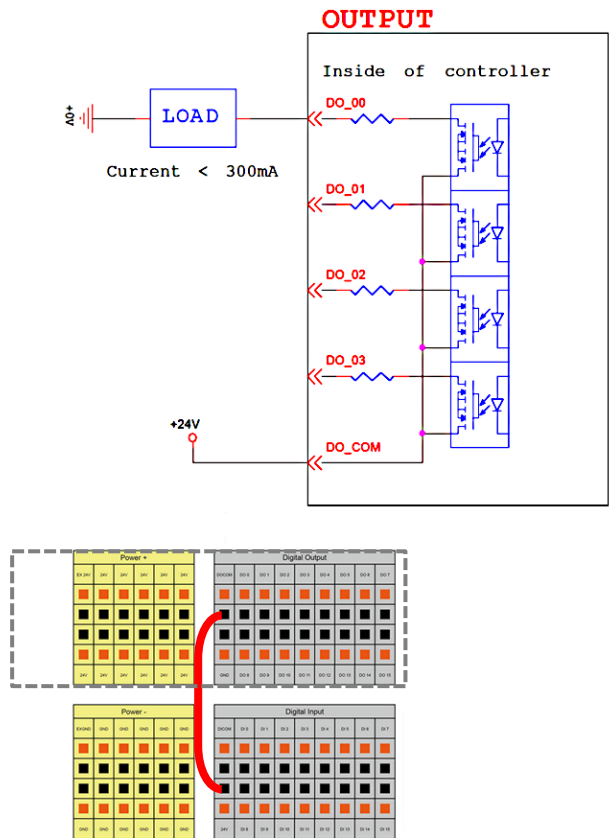

Figure 41: Set to Source Output Type

5.3.4 Analog In

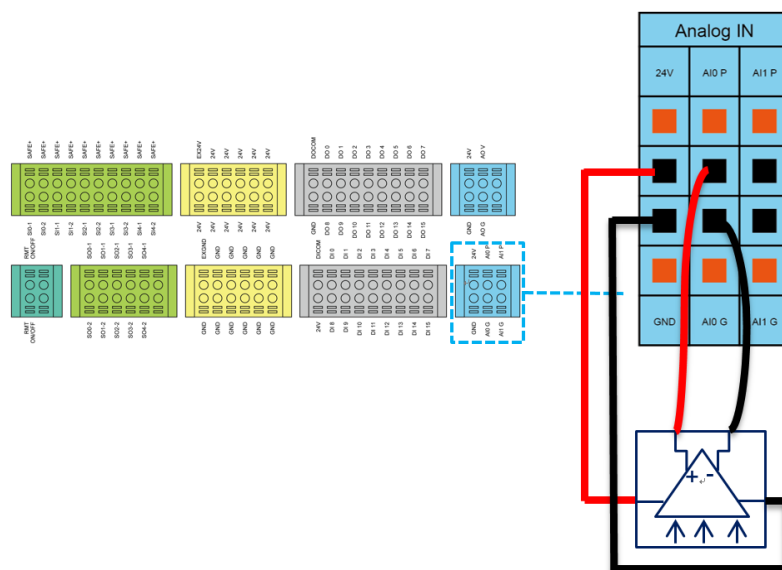

Figure 42: Analog In

5.3.5 Analog Out

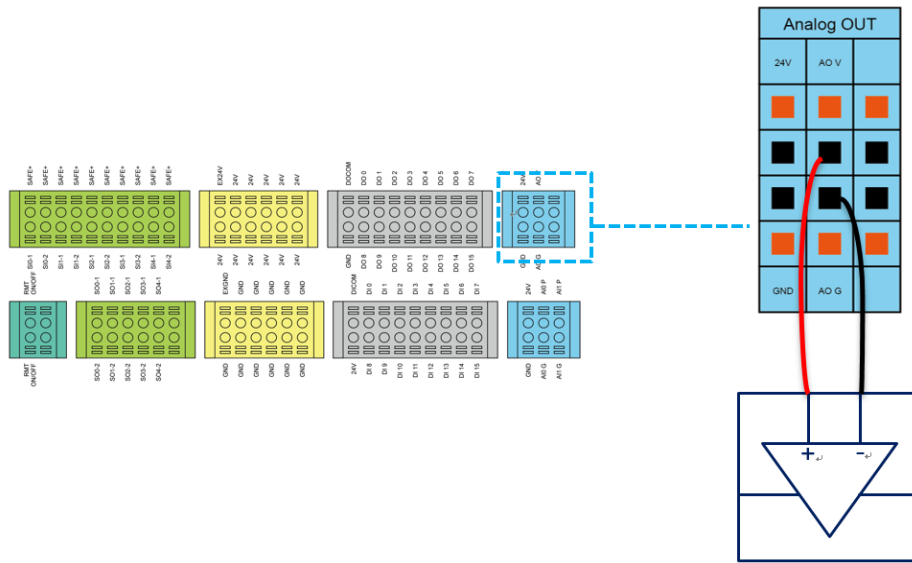

Figure 43: Analog Out

	Range	Resolution	Accuracy	Conversion Time
Analog In	+10.00V~-10.00V	11bit	≤ 0.2%	1 ms
Analog Out	+10.00V~-10.00V	11bit	± 0.07%	1 ms

Table 11: Analog In & Analog Out

5.3.6 System Remote Power ON/OFF

The function of Remote ON/OFF shares the same functionality of the Robot Stick Power Button.

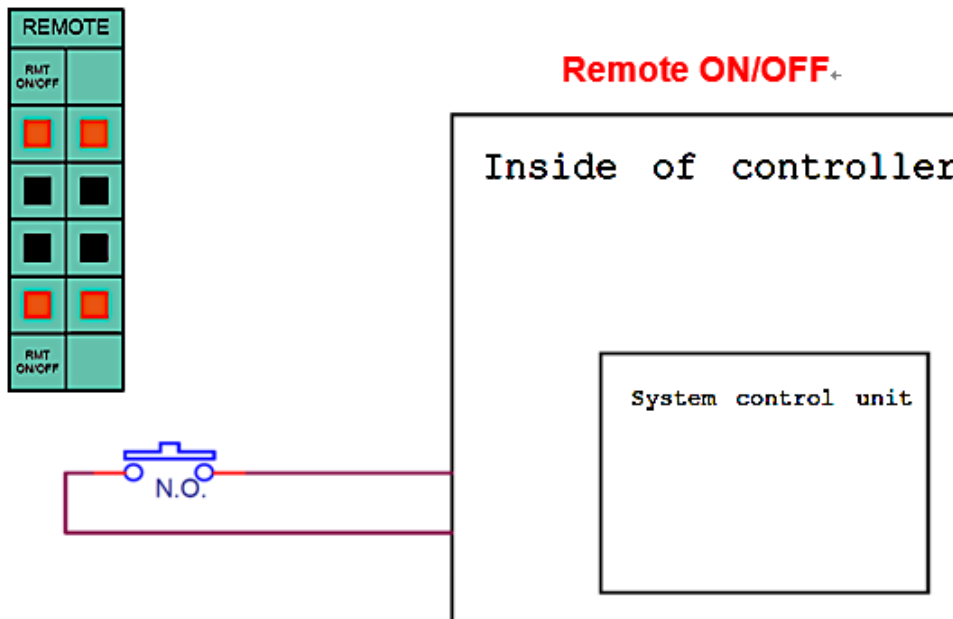

Figure 44: System Remote Power ON/OFF

5.3.7 EtherCAT: For EtherCAT Slave I/O Expansion

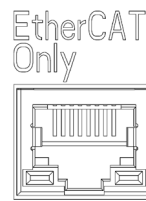

Figure 45: EtherCAT



WARNING:

The robot must be powered off when installing the EtherCAT Slave. Do not plug or unplug the connector while the robot is on.

5.3.8 USB Port

The USB port of the control box is used for connecting the keyboard, mouse and external storage devices. External storage devices should only be used for the import/export functions of TMflow. No other device than those listed above should be connected. Be noted that the external storage device should be labelled **TMROBOT**.

5.4 Tool End I/O Interface

There are two small connectors on the tool end of the robot: the 8-pin connector is for digital I/O and the 5-pin connector is for analog I/O.

5.4.1 I/O Terminals

The tool end 24V has a total maximum output current of 1.5A included 900mA of the light module. If overloaded, overload protection is activated and the robot will turn off the 24V output power.

Pin	Wire color	Pin define	
1	Brown	+24v	24V output
2	Red	DI_0	Digital Input0
3	Orange	DI_1	Digital Input1
4	Yellow	DI_2	Digital Input2
5	Green	DO_0	Digital Output0
6	Blue	DO_1	Digital Output1
7	Purple	DO_2	Digital Output2
8	Black	+0V	+0v

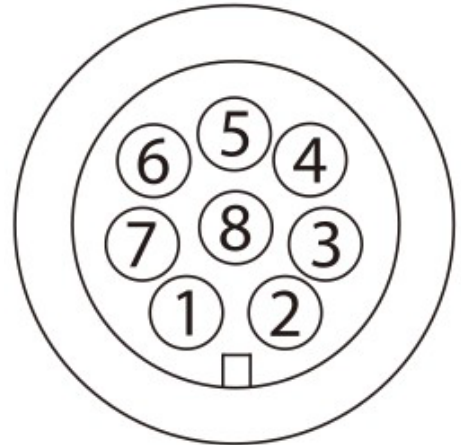

*The M8/8PIN connector complies with the regulation of IEC 61076-2-104.

Table 12: 8-pin Digital I/O Connectors of Cable

Pin	Wire Color	Pin Define	
1	Brown	+24v	24V output
2	Red	DI_0	Digital input0
3	Orange	DI_1	Digital input1
4	Yellow	DI_2	Digital input2
5	Green	DO_0	Digital output0
6	Blue	DO_1	Digital output1
7	Purple	DO_2	Digital output2
8	Black	+0V	+0V



Table 13: 8-pin Digital I/O Connector of Robot

Pin	Wire Color	Pin Define	
1	Black	+24V	24V output
2	Brown	DI_3	Digital Input3
3	Red	DO_3	Digital Output3
4	Orange	AI Analog	Input
5	Yellow	+0V	GND

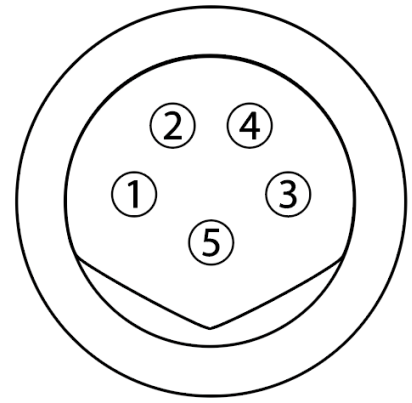

*The M8/5PIN connector complies with the regulation of IEC 61076-2-104.

Table 14: 5-pin Analog I/O Connector of Cable

Pin	Wire Color	Pin Define	
1	Black	+24V	24V output
2	Brown	DI_3	Digital Input3
3	Red	DO_3	Digital Output3
4	Orange	AI Analog	Input
5	Yellow	+0V	GND

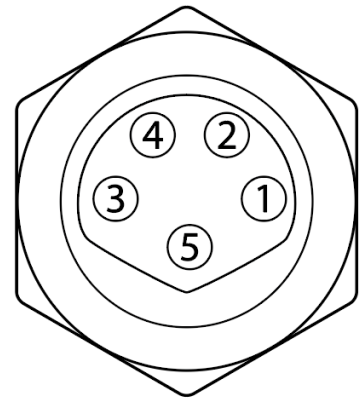

Table 15: 5-pin Analog I/O connector of Robot

5.4.2 Connecting Tool End Digital Output

The following figure shows how to connect the tool end digital output:

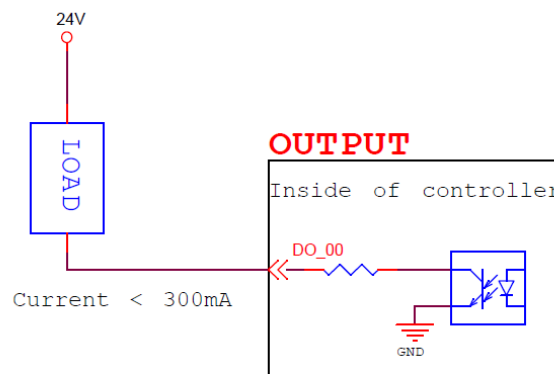

Figure 46: Connecting Tool End Digital Output

5.4.3 Connecting Tool End Digital Input

The following figure shows how to connect the tool end digital input:

NOTE: If sensors are connected directly then they should be NPN.

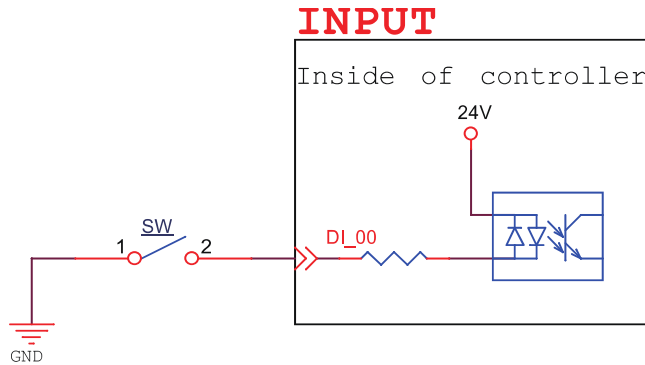

Figure 47: Connecting Tool End Digital Input

5.4.4 Connecting Tool End Analog Input

Range	Resolution	Accuracy	Conversion Time
+10.00V~-10.00V	11bit	≤ 0.2%	1 ms

Table 16: Analog Input Range

The following figure shows how to connect the tool end Analog input:

(Because AIN_GND is connected to ground, when AIN is a dead contact, a pressure difference will occur, which is a normal phenomenon.)

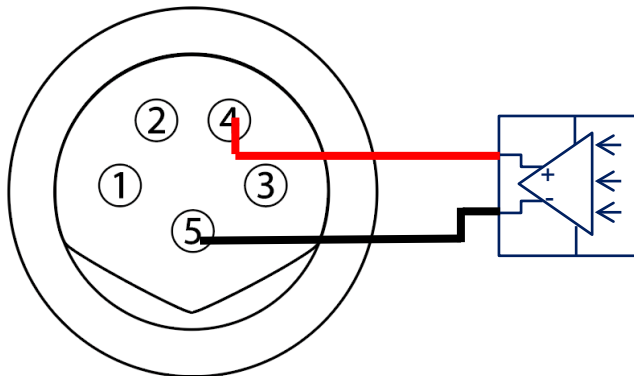

Figure 48: Connecting Tool End Analog Input

5.5 Control Box Interfaces

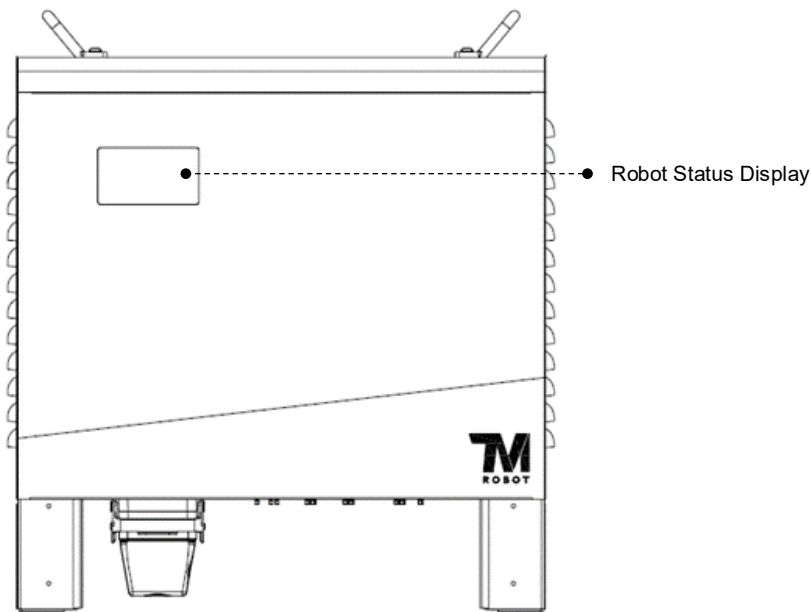

Figure 49: Front View of the Control Box



CAUTION:

The ETHERCAT interface can only be used to connect ETHERCAT devices. Improper connection may cause the robot to stop.

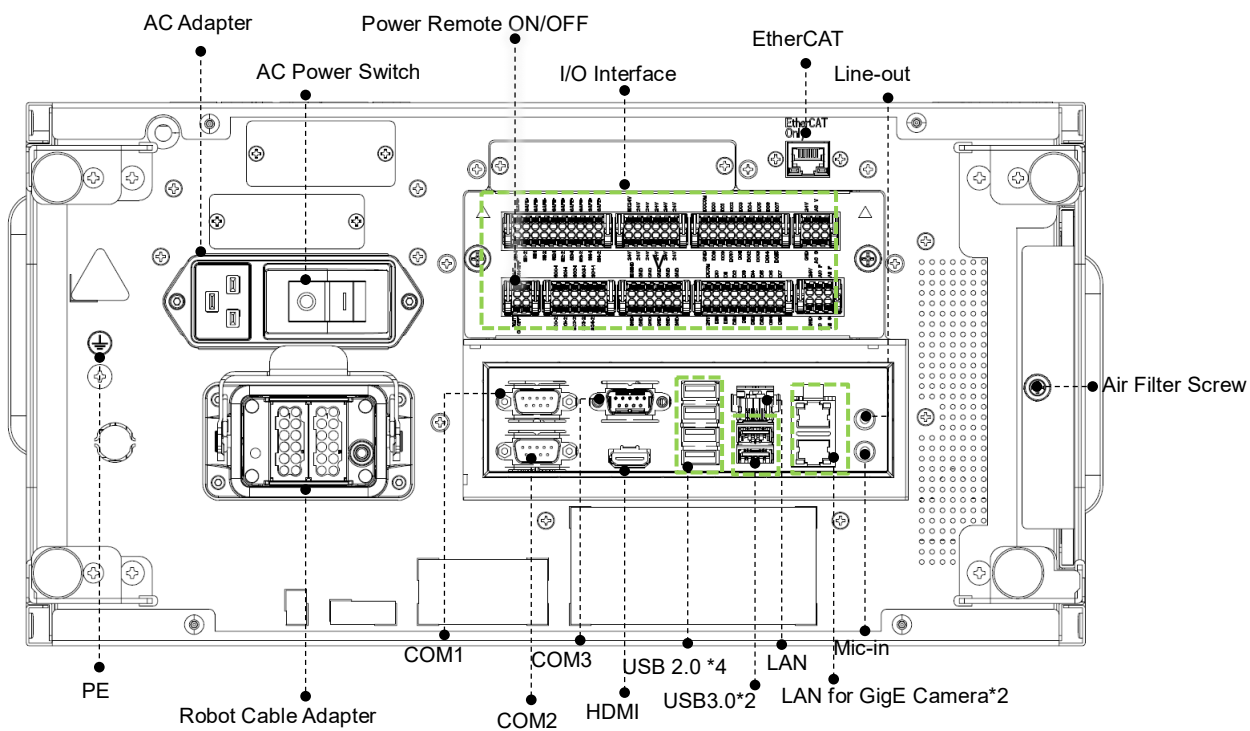

Figure 50: Interfaces of the TM16 / TM16X Series

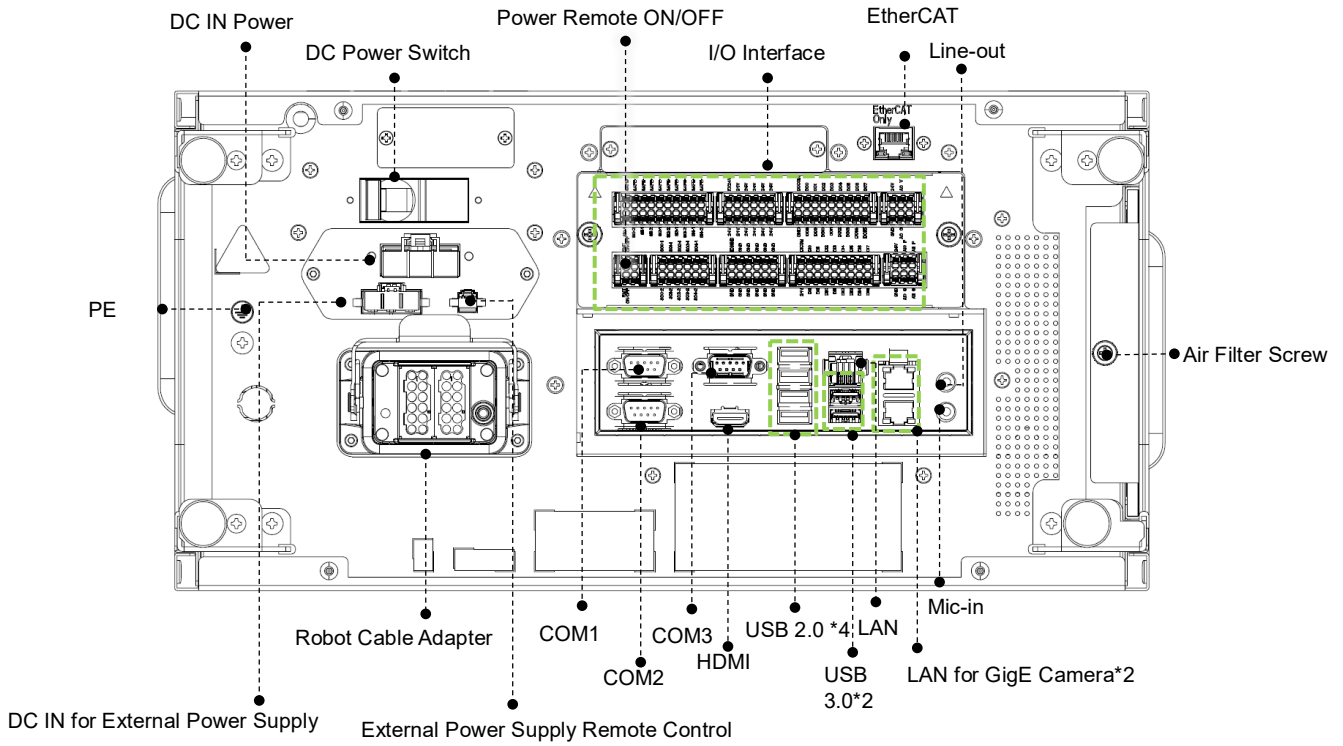

Figure 51: Interfaces of the TM16M Series

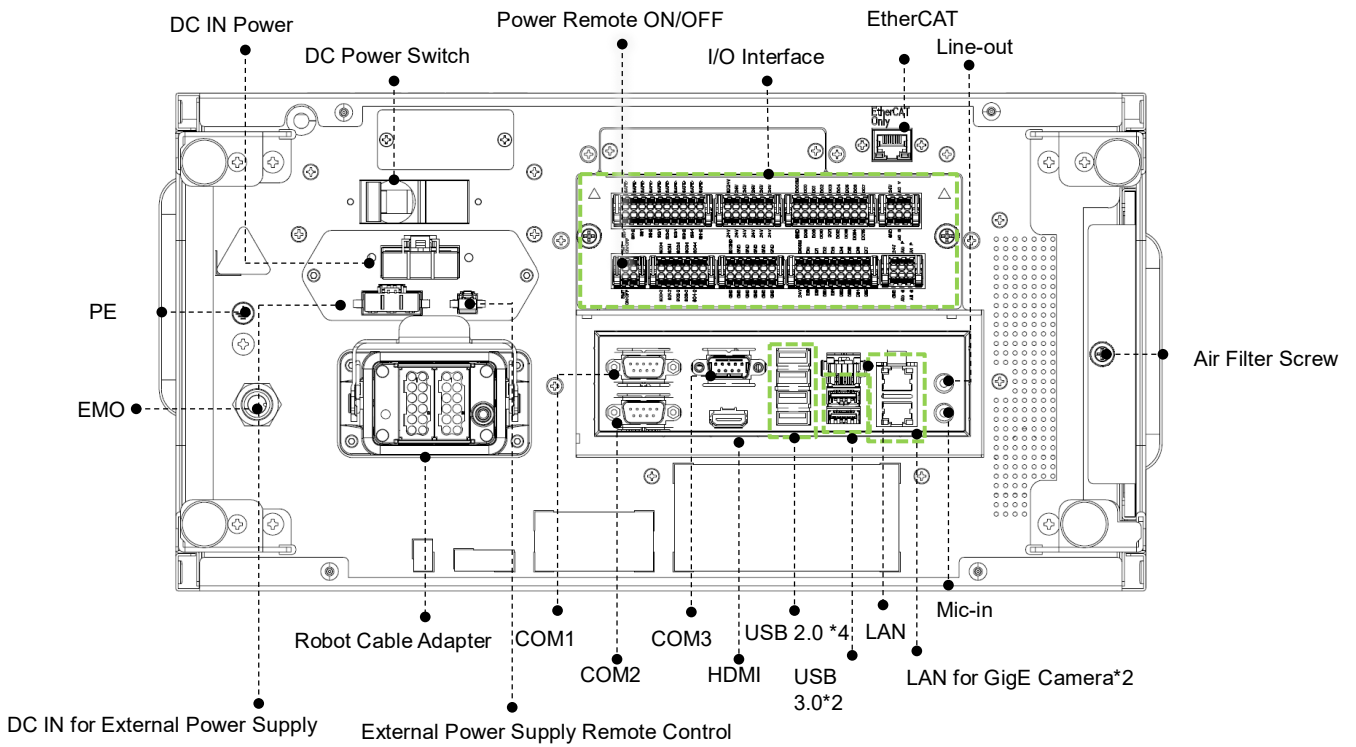

Figure 52: Interfaces of the TM16M SEMI Series

5.6 Control Box Power Interface and Robot Interface

5.6.1 Control Box Power Interface

TM16 / TM16X:

The power cable of the control box has an IEC plug. The local power plug is connected to the IEC plug. The AC power switch must be in OFF state before plugging in or out the power cable.

TM16M:

The power cable of the control box has Hirose (HRS) DF60 series connector.

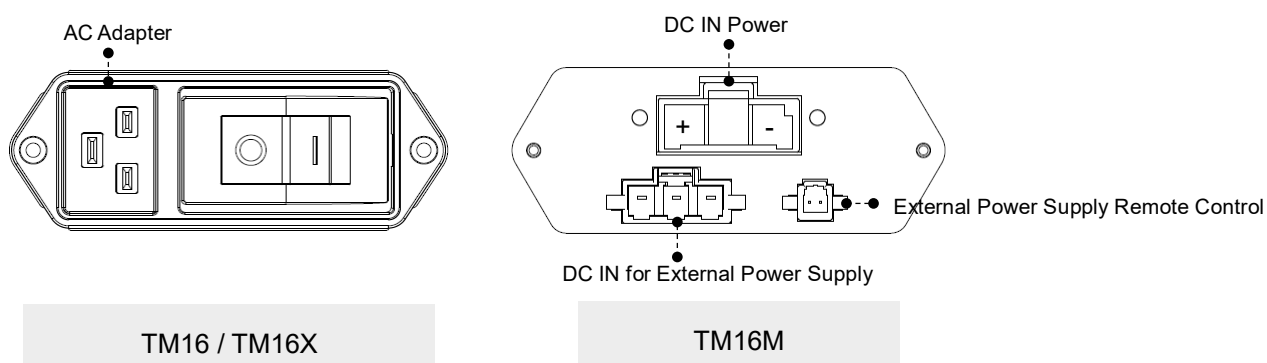

AC Adapter : IEC plug

DC IN Power Connector : (HRS) DF60-3EP-10.16C

DC IN for External Power Supply Connector : Contact the Corporation for purchasing

External Power Supply Remote Control Connector : Contact the Corporation for purchasing

Figure 53: Control Box Power Interfaces

The power supply should be equipped with the following:

- Grounding
- Main fuse
- Residual current device (RCD)

It is recommended to install a master switch on the equipment power supply for robot applications for servicing and inspection.

Parameters	Minimum value	Typical value	Maximum value	Unit
Input voltage	100	-	240	VAC
External mains fuse (100V~120V)	-	-	15	A

External mains fuse (220V~240V)	-	-	10	A
Input frequency	43	-	63	Hz

Table 17: TM16 / TM16X Series Electrical Specifications

*If using AC100V~AC199V power supply, the Robot will automatically limit the total output power

Parameters	Minimum Value	Typical value	Maximum value	Unit
Input voltage	22	-	60	V (DC)
Power consumption		300	1500	W

Table 18: TM16M Series Electrical Specifications

*If using DC22~47V power supply or operating at high speed, the Robot will automatically limit the total output power.

*The maximum power consumption of TM16M series defaults to 1500W. For applications with more power consumptions, please contact the Corporation to purchase the external power supply.



DANGER:

1. Ensure that the robot is correctly grounded (electrical grounding).
2. Ensure that the input current of the control box is protected by the Residual Current Device (RCD) and appropriate fuses.
3. Ensure that all cables are correctly connected before the control box is energized. Always use genuine power cables correctly.

5.6.2 Robot Interface

The following figure shows the connection interface of the robot. The cables of the robot are connected to the control box through the interface.

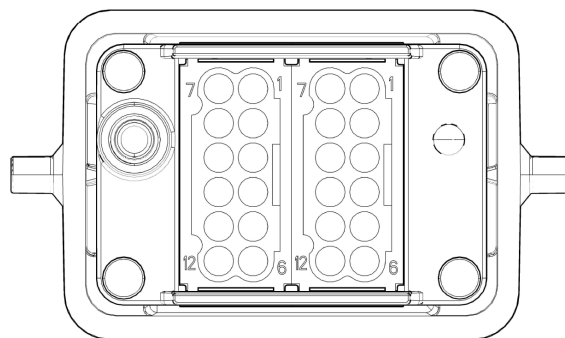

Figure 54: Robot Interface



WARNING:

1. When the robot is turned on, do not disconnect the cable of robot. When the cable of robot is not connected to the connection interface, do not turn on the robot.

2. Do not extend or modify the original cable of robot.
3. The cable of the robot is only suitable for a fixed installation. If the applications have the request for flexible or longer cable, contact the corporation.

5.6.3 SEMI Emergency Off Interfaces (SEMI series exclusive)

Refer below for the SEMI Emergency Off interfaces. The SEMI Emergency Off switch is connected with control box through the EMO port. Please remove the padlock on the power interface for the power cable or the power switch, and secure the padlock back to the box with the screws for shipping the box.

5.6.3.1 TM16M SEMI Series

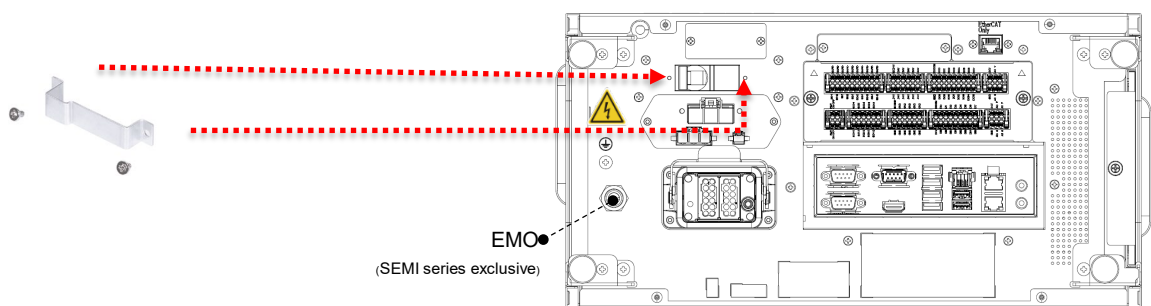

Figure 55: The TM16M SEMI SEMI Emergency Off Interface



CAUTION:

For SEMI series, when SEMI Emergency Off Switch is not connected with EMO, the TM Robot cannot be booted.



WARNING:

When SEMI Emergency Off Switch is pressed, all power will be cut off immediately. This action impacts on the motion of the robot. Users should take with caution.

5.6.4 Detachable I/O Panel

To facilitate the wiring of the detachable I/O panel which comes with a 15 cm cable, users can loosen the tethered screws to remove the detachable I/O panel and install easily in the other place. Users are free to change the cable for the placement farther away; however, it is suggested to use the cable no longer than 3 m. The box header connector comes with 40 pins and 44 pins in spacing for 2.54 mm.

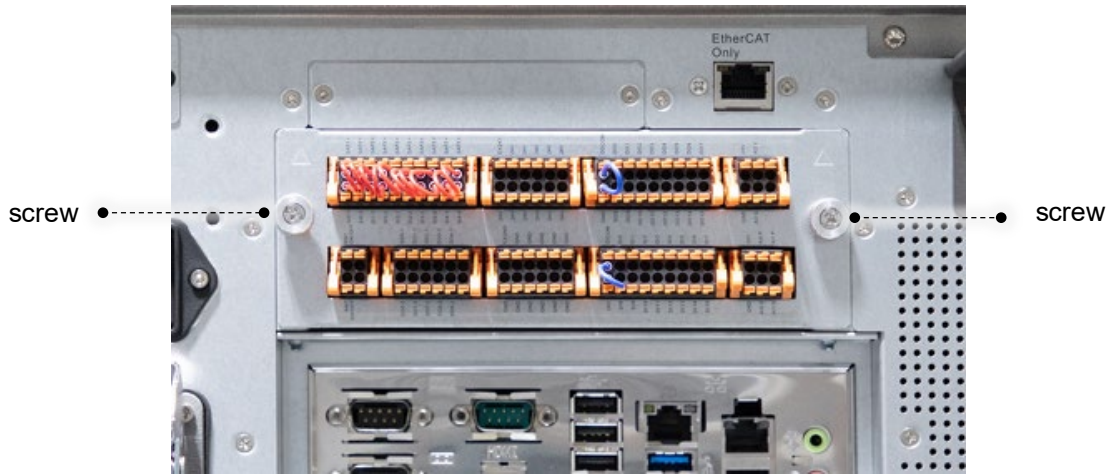

Figure 56: Detachable I/O Panel



NOTE:

The control box comes with the IP32 rating, but the Corporation does not guarantee this rating for disassembling detachable I/O panel from its original location.

6. Unboxing & Installation

6.1 Overview

These instructions guide Users of the TM Robot through the first set up. Users must thoroughly read and understand this Guide before performing the operations of this Chapter. Fail to do so may cause serious danger.



WARNING:

If this is your first time using the TM Robot, follow instructions in this chapter to perform installation and initial set up. If the robot has been implemented in the working environment, please note the following:

1. To avoid potential hazards after changing the original environment setting, verify with current responsible operator and to back up all necessary software settings and hardware wirings scheme.
2. Remove all of the control box's external I/O connections including the analog I/O, EtherCAT port and network port. Remove all air lines or external power lines connected to the optional equipment before Commissioning.
3. Remove all of the control box's connections to external devices / external storage devices through USB interface, Serial port, and network interface.
4. Unload any object/end effector attached to the end flange, and any electrical connection between the end effector and end module / control box of the robot.
5. Unload any hardware attached to the robot arm.

6.2 Inspecting the Equipment

6.2.1 Before Unpacking

Carefully inspect all shipping crates for evidence of damage during transit. If any damage is indicated, request that the carrier's agent be present at the time the container is unpacked

6.2.2 Upon Unpacking

Before signing the carrier's delivery sheet, compare the actual items received (not just the packing slip) with your equipment purchase order and verify that all items are present and that the shipment is correct and free of visible damage. If the items received do not match the packing slip or are damaged, do not sign the receipt, contact your corporation support as soon as possible. If the items received do not match your order, contact your corporation support immediately. Inspect each item for external damage as it is removed from its container. If any damage is evident, contact your corporation support (see HOW Can I Get Help? on 1.2)

Retain all shipping containers and packaging materials. These items may be necessary to settle claims or at a later date, to relocate equipment.

6.3 Unboxing

6.3.1 Carton Types

The TM Robot product comes with 2 cartons: the robot arm carton, and the control box carton, as shown below. Also, a SEMI Emergency OFF switch carton will come along with the SEMI series. For TM16 SEMI, there will be an additional carton comes with the SEMI Emergency OFF Box. Refer below for the ratio of the cartons. The actual sizes of the cartons may differ from measurements

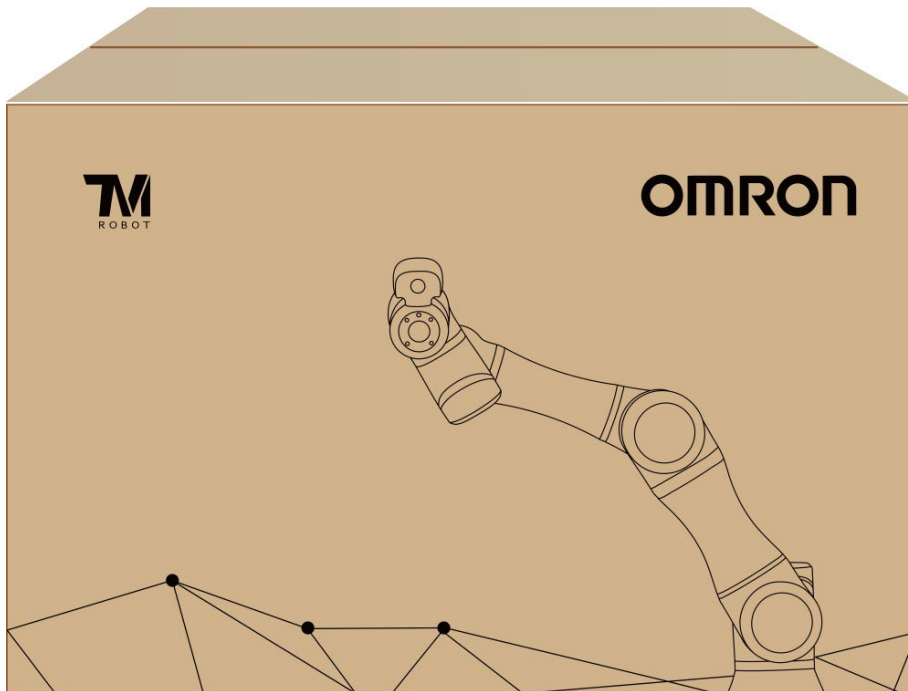

Figure 57: Robot Arm Carton

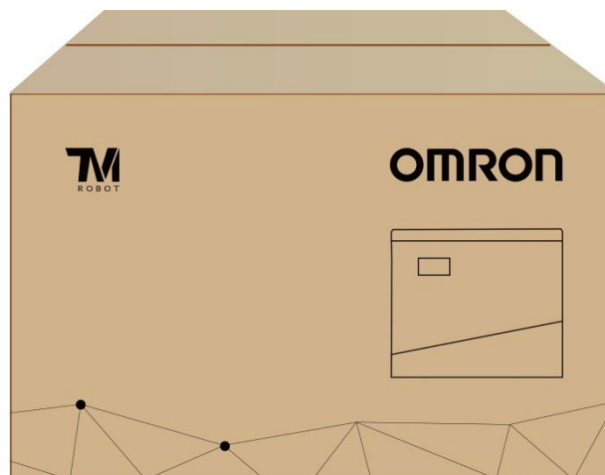

Figure 58: Control Box Carton

6.3.2 Contents of Each Carton

Each carton has the following contents. Check them when you unpack the cartons for the first time. If any item is missing, contact your vendor.

The robot arm carton contains:







	<p style="text-align: center;">Robot arm</p> <p>Cable length: 300 cm</p>
---	---

Table 19: The Robot Arm Carton Contents

The control box carton contains:

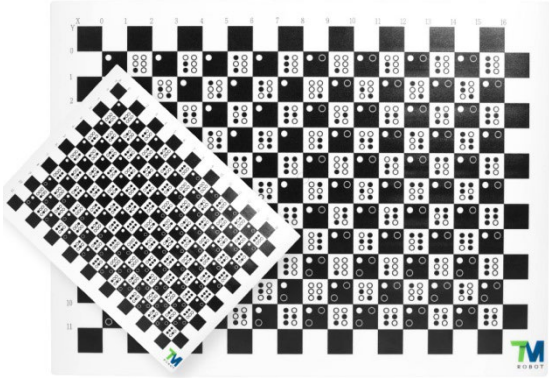
	<p style="text-align: center;">Control box</p>
	<p style="text-align: center;">Product Brief Information</p>

	<p>Calibration Plates</p> <p>(One large calibration plate and one small calibration plate. Peel the protective wrap off before using.) *The Calibration Plate comes only with TM Robots fitted with the hand-eye camera.</p>
	<p>IO cables</p> <p>(One 8-pin digital I/O cable and one 5-pin analog I/O cable) Length: 100 cm</p>
	<p>TM Landmark</p> <p>(Two Landmarks. Peel the protective wrap off before using.) *The Landmark comes only with TM robots fitted with the hand-eye camera. Landmark size: 50.5 * 50.5 mm (tolerance ± 0.1 mm)</p>
	<p>Power cord of the control box (TM16 / TM16X)</p> <p>(3 cable, Type B, G, F) Cable Length: 180 cm</p>
	<p>Power cable of the control box (TM16M)</p> <p>(1 cable) Length: 120 cm</p>



	<p style="text-align: center;">Ground Wire</p> <p>(2 wires) Length: 200 cm</p>
	<p style="text-align: center;">Jumper Wire</p> <p>(1 pair) Wire Length: 3 cm</p>

Table 20: The Control Box Carton Contents

6.4 Installing Your Robot

The TM Robot arm cannot stand independently after being removed from the carton. Therefore, prepare the mounting base with the corresponding holes as described in 4.2.1.6 Robot Arm Installation, and follow the instructions below to install the robot.



WARNING:

At the installation site, at least two people should simultaneously perform installation of the robot; otherwise you risk robot arm damage or personal injury. Do not install the robot alone.



WARNING:

Do not attempt to move any robot links until the robot has been secured in position. Failure to comply could result in the robot falling and causing either personnel injury or equipment damage.

6.4.1 Remove the Control Box

After checking the contents, remove the contents in order and perform installation.

Control box carton:

- Remove the Calibration Plates and TM Landmark
- Remove the power cable of the control box
- Remove the control box (At least two people should remove the control box from the carton. Refer the figure below for the correct holding positions.)
- Connect the power cable to the control box

- Place the control box near the robot base



Figure 59: Moving the Control Box (1/2)

The control box should be carried by at least two people. One should hold on to the control box handles, while the other should carry the foot stands. Before handling, the cable of the robot stick should not be pulled to avoid any performance degradation.



Figure 60: Moving the Control Box (2/2)



WARNING:

At this stage, do not connect the power cable of the control box to any electrical outlet, or it may cause equipment damage.

6.4.2 Verification Before Removal of the Robot Arm

The TM Robot arm cannot stand independently after being removed from the carton. Prepare four screws (M10 *4) that used to attach the robot to the base near the robot base in advance. If the base is designed with corresponding pinholes, mount them to the base.

6.4.3 Removal of the Robot Arm and Tightening

At least two people should remove the robot arm from the carton. For the correct holding positions, refer to the figure below. Place the robot on the mounting base. If it is designed with connection pins, align the pinholes of the robot base module. Tighten two locking screws with metal washers for the robot base that are diagonally across from each other, and then tighten the other two locking screws.

Follow the tightening torque recommended in 4.2.1.6 Robot Arm Installation



Figure 61: Moving the Robot Arm (1/2)

The Robot Arm itself should be handled with at least two people. One person should carry the Lower arm and Upper arm, and the other should hold on to the position between the base and 1st Joint as well as the 6th Joint. Before the Robot Base is fastened with screws tightly, the Robot Arm should always be supported to avoid tipping.



Figure 62: Moving the Robot Arm (2/2)



WARNING:

When the robot is installed to the base, make sure two people work together to install it. If it is designed with pinholes, pay attention to your safety to avoid pinching. If you do not have connection parts at hand, such as the connecting pins and screws, do not leave the robot without completely tightening it (with the 4 screws completely tightened). One person should continuously support the robot arm while the other person goes to get required parts. Otherwise, the robot arm may tip, result in equipment damage or personal injury.

For users of TM16 SEMI, please remove the SEMI Emergency OFF Box out of its carton. For the correct holding positions, refer to the figure below.



Figure 63: Moving the SEMI Emergency OFF Box

6.4.4 Connect the Robot and the Control Box

1. Connect the cable from the robot to the robot interface of the control box.
2. Connect the power cable between the wall socket and the power interface of the control box.

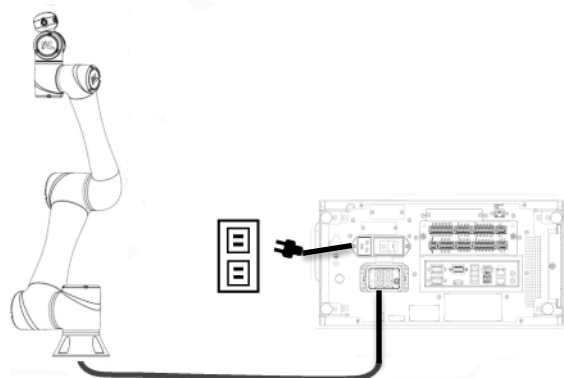

Figure 64: Connecting the Robot and the Control Box

For the SEMI series users only, connect the SEMI Emergency OFF switch to the EMO interface of the control box.



WARNING:

1. Ensure that all cables are correctly connected before the control box is energized. Always use genuine power cables correctly.
2. When the robot is turned on, do not disconnect cables of the robot. When cables of the robot are not connected to the connection interface, do not turn on the robot.
3. Do not extend or modify the original cables of the robot.

7. Maintenance and Repair

The following table gives a summary of the preventive maintenance procedures and guidelines:

Items	Period	Remark
Warning, Safety labels	1 week	Ensure labels are present and legible. Replace them if necessary.
Check Filter	1 month	Replace filter every 3 months.
Check Emergency Switch	1 month	Press the Emergency Switch and the IO E-Stop in open-loop status. Verify that each shuts off power.
Check User Connected External Safeguard Input Port, User Connected External Safeguard Input Port for Human–Machine Safety Settings, & User Connected Enabling Device Input Port	1 month	When the User Connected External Safeguard Input Port is open, the current motion is supposed to stop, and the indication light of current mode will be constantly flashing. When the User Connected External Safeguard Input Port for Human–Machine Safety Setting is open, the purple light will be alternating between the indication light of the current mode. When the User Connected Enabling Device Input Port is open, the current motion is supposed to stop, and the indication light of current mode will be constantly flashing. This function is invalid in auto mode.
Check Robot Mounting Screws	3 months	Follow "4.2.1.6 Robot Arm Installation"
EMO button (SEMI version only)	6 months	Press the EMO button. Verify that power shuts off.

Table 21: Summary of the Preventive Maintenance Procedures and Guidelines

Only the legal distributor or authorized service center should repair the TM Robot. Users should not repair it by themselves.



DANGER:

Before performing maintenance or service record the details of each setting for the robot for normal operation. Make sure that each setting satisfies the original conditions before resuming normal operation, including but not limited to:

- Safety Software Settings

- Safety I/O
- Preset operation project
- TCP Settings
- I/O Settings
- I/O Wiring

NOTE:

The filter must be changed regularly to maintain efficiency. Please contact the Corporation to purchase the filter if in demand.

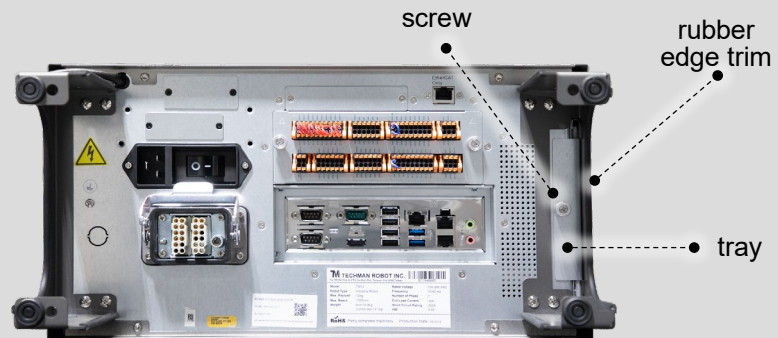

Figure 65: Air Filter Tray

Removal method:

1. Turn of the power and lay the control box flat.
2. Remove the rubber edge trim and loosen the air filter screw.
3. Pull out the air filter tray and replace the filter with a new one.

Appendix A. Technical Specifications

Model	TM16	TM16M	TM16X	TM16MX
Weight	32 kg	32 kg	32 kg	32 kg
Maximum Payload	16 kg	16 kg	16 kg	16 kg
Reach	900 mm	900 mm	900 mm	900 mm
Joint ranges	J1,J6	+/- 270°	+/- 270°	+/- 360°
	J2,J4,J5	+/- 180°	+/- 180°	+/- 360°
	J3	+/- 155°	+/- 155°	+/- 155°
Speed	J1, J2	120°/s		
	J3~J6	180°/s		
Typical Speed	1.1 m/s			
Maximum Speed	4 m/s			
Repeatability	+/- 0.1 mm			
Degrees of freedom	6 rotating joints			
I/O ports	Control Box	Digital In: 16 Digital Out: 16 Analog In: 2 Analog Out: 1		
	Tool Conn.	Digital In: 4 Digital Out: 4 Analog In: 1 Analog Out: 0		
I/O power supply	24V 2.0A for control box and 24V 1.5A for tool			
IP classification	IP54 (Robot Arm); IP32 (Control Box)			
Power consumption	Typical 300 watts			
Temperature	The robot can work in a temperature range of 0-50°C			
Power supply	100-240 VAC, 50-60 Hz	22-60 VDC		
I/O Interface	3×COM, 1×HDMI, 3×LAN, 4×USB2.0, 2×USB3.0			
Communication	RS232, Ethernet, Modbus TCP/RTU (master & slave), PROFINET (optional), EtherNet/IP (optional)			
Programming Environment	TMflow, flowchart based			
Certification	CE, SEMI S2 (optional), ISO 10218-1 & ISO/TS 15066			
Robot Vision				
Eye in Hand (Built in)	1.2M/5M pixels, color camera	N/A		
Eye to Hand (Optional)	Support Maximum 2 GigE 2D cameras			

*Refer to the official website of TM Plug&Play for camera models compatible to TM Robot.

Table 22: Technical Specifications

OMRON Corporation **Industrial Automation Company**
Kyoto, JAPAN **Contact: www.ia.omron.com**

Regional Headquarters

OMRON EUROPE B.V.
Wegalaan 67-69, 2132 JD Hoofddorp
The Netherlands
Tel: (31)2356-81-300/Fax: (31)2356-81-388

OMRON ASIA PACIFIC PTE. LTD.
No. 438A Alexandra Road # 05-05/08 (Lobby 2),
Alexandra Technopark,
Singapore 119967
Tel: (65) 6835-3011/Fax: (65) 6835-2711

OMRON ELECTRONICS LLC
2895 Greenspoint Parkway, Suite 200 Hoffman Estates,
IL 60169 U.S.A.
Tel: (1) 847-843-7900/Fax: (1) 847-843-7787

OMRON ROBOTICS AND SAFETY TECHNOLOGIES, INC.
4225 Hacienda Drive, Pleasanton CA 94588 U.S.A.
Tel: (1) 925-245-3400/Fax: (1) 925-960-0590

OMRON (CHINA) CO., LTD.
Room 2211, Bank of China Tower, 200 Yin Cheng Zhong Road,
PuDong New Area, Shanghai, 200120, China
Tel: (86) 21-5037-2222/Fax: (86) 21-5037-2200

Authorized Distributor:

© Techman Robot Inc.2022 All Rights Reserved
In the interest of product improvement,
specifications are subject to change without notice.

Cat. No. I678-E-01

0622

19888-210 A