

G9SP Series

Safety Controller

HOST CONNECTION MANUAL

OMRON

© **OMRON, 2010**

All rights reserved. No part of this publication may be reproduced, stored in a retrieval system, or transmitted, in any form, or by any means, mechanical, electronic, photocopying, recording, or otherwise, without the prior written permission of OMRON.

No patent liability is assumed with respect to the use of the information contained herein. Moreover, because OMRON is constantly striving to improve its high-quality products, the information contained in this manual is subject to change without notice. Every precaution has been taken in the preparation of this manual. Nevertheless, OMRON assumes no responsibility for errors or omissions. Neither is any liability assumed for damages resulting from the use of the information contained in this publication.

Introduction

Thank you for purchasing a G9SP-series Safety Controller. This manual contains information required to use the G9SP-series Controller. Please thoroughly read and understand this manual before you use the G9SP-series Controller.

Internded Audience

This manual is intended for the following personnel, who must also have knowledge of electrical systems (an electrical engineer or the equivalent).

- Personnel in charge of installing FA systems.
- Personnel in charge of designing FA systems.
- Personnel in charge of managing FA systems and facilities.
- Personnel in charge of qualifications and authority in all phases, including system design, installation, operation, maintenance, and disposal.

Manual Configuration

Information on the operation of G9SP-series Safety Controllers is provided in the following manuals. Refer to the specific manual depending on the information that is required.

Manula name	Contents	Cat. No.
G9SP-series Safety Controller Host Connection Manual (this manual)	This manual provides sample ladder programming and describes how to connect to a Standard PLC from another manufacturer using the communications functionality of the G9SP-series Controller's Option Board. The procedure for connecting to a Standard PLC from another manufacturer is described in the G9SP Operation Manual.	Z924
G9SP-series Safety Controller Operation Manual	This manual provides detailed specifications and describes functions and application methods for the G9SP-series Controller in detail.	Z922
G9SP-series Safety Controller Instructions Reference Manual	This manual describes the safety programming methods, provides the specifications, and describes the functions and operating methods of the G9SP-series Controllers.	Z923

Table of Contents

Introduction	1
Manual Configuration	2
Table of Contents	3

Section 1 Connecting to OMRON PLCs

1 - 1	Functionality	1-2
1 - 2	RS-232C Serial Communications	1-3
1 - 3	Ethernet Communications	1-4

Section 2 Connecting to Mitsubishi Electric PLCs

2 - 1	Functionality	2-2
2 - 2	RS-232C Serial Communications	2-3
2 - 2 - 1	Communication Format	2-3
2 - 2 - 2	Application Example 1(Connecting to the Mitsubishi Standard PLC Q Series)	2-3
2 - 2 - 3	Application Example 2(Connecting to the Mitsubishi Standard PLC FX Series)	2-10
2 - 3	Ethernet Communications	2-16
2 - 3 - 1	Communication Format	2-16
2 - 3 - 2	Application Example	2-16

Section 3 Connecting to Siemens PLCs

3 - 1	Functionality	3-2
3 - 2	RS-232C Serial Communications	3-3
3 - 2 - 1	Communication Format	3-3
3 - 2 - 2	Application Example	3-3
3 - 3	Ethernet Communications	3-11
3 - 3 - 1	Communication Format	3-11
3 - 3 - 2	Application Example	3-11



1

Connecting to OMRON PLCs

This section describes how to perform communications with OMRON standard PLC through an RS-232C Option Board or Ethernet Option Board.

1 - 1	Functionality.....	1-2
1 - 2	RS-232C Serial Communications	1-3
1 - 3	Ethernet Communications.....	1-4

1 - 1 **Functionality**

Refer to **Section 7 Communications with a Standard PLC Using an Option Board** of the **G9SP Series Safety Controller Operation Manual (Cat. No. Z922)**.

1 - 2 RS-232C Serial Communications

Refer to **Section 7 Communications with a Standard PLC Using an Option Board** of the **G9SP Series Safety Controller Operation Manual (Cat. No. Z922)**.

1 - 3 Ethernet Communications

Refer to **Section 7 Communications with a Standard PLC Using an Option Board** of the **G9SP Series Safety Controller Operation Manual (Cat. No. Z922)**.

2

Connecting to Mitsubishi Electric PLCs

This section describes how to perform communications with Mitsubishi Electric Standard PLC through an RS-232C Option Board or Ethernet Option Board.

2 - 1	Functionality.....	2-2
2 - 2	RS-232C Serial Communications	2-3
2 - 2 - 1	Communications Format	2-3
2 - 2 - 2	Application Example 1(Connecting to the Mitsubishi Standard PLC Q Series.)	2-3
2 - 2 - 3	Application Example 2(Connecting to the Mitsubishi Standard PLC FX Series.)	2-10
2 - 3	Ethernet Communications.....	2-16
2 - 3 - 1	Communications Format	2-16
2 - 3 - 2	Application Example	2-16

2 - 1 Functionality

Refer to Section 7 Communications with a Standard PLC Using an Option Board of the G9SP Series Safety Controller Operation Manual (Cat. No. Z922).

2 - 2 RS-232C Serial Communications

This section provides a description and example of connection to a Mitsubishi Electric Standard PLC. The No-protocol communications are available for connection with a Mitsubishi Electric Standard PLC.

2 - 2 - 1 Communications Format

Refer to Section 7 Communications with a Standard PLC Using an Option Board of the G9SP Series Safety Controller Operation Manual (Cat. No. Z922).

2 - 2 - 2 Application Example 1(Connecting to the Mitsubishi Standard PLC Q Series.)

System Configuration

This section uses the following example to describe how to access the G9SP-series Controller by performing serial communications through a RS-232C Serial Communications Board (CP1W-CIF01) from a Mitsubishi Electric Standard PLC Q series.

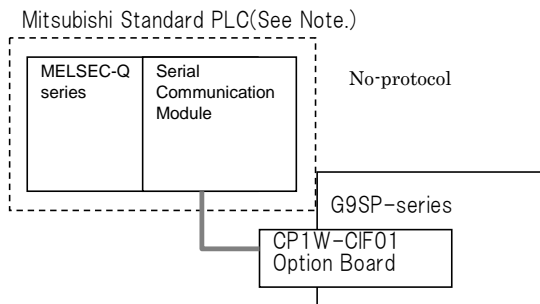

Note: This example uses the following Mitsubishi Electric Standard PLC.

Product	Model/version
CPU Unit (Standard PLC)	Q02HCPU
Serial Communication Module	QJ71C24N-R2
Support Software (for setup and creating ladder programs)	GX Developer Version 8.90U GX Configurator-SC Version2.21X

G9SP-series Controller Settings

Settings are not required. Make the communications settings in the Mitsubishi Electric Standard PLC to match the serial communications specifications of the G9SP-series Controller.

Mitsubishi Electric PLC Q series Settings

Set serial communication module CH2 as given below in the PLC parameter using the GX Developer and CH2 No-protocol system setting using the intelligent function utility.

- PLC parameter settings

Set serial communication module CH2 as given below in the PLC parameter by selecting[Project data list]-[Parameter]-[PLC parameter]-[I/O assignment].

Parameter	Description	Set value for this example
Communication protocol setting	Communication protocol	Non-procedure
Transmission setting	Transmission setting	Data bit :8bits Parity bit :Yes Odd/even parity:Even Stop bit :1bit Sum check code :No
Communication rate setting	Baud rate	9600bps

- Intelligent function utility settings

Set serial communication module CH2 as given below in the CH2 Non procedure system setting by selecting [Tools]-[Intelligent function utility]-[Start].

Parameter	Description	Set value for this example
Received data count designation	Received data count	00C7(199bytes)
Receive complete code designation	Receive complete code	FFFF(Not designated)

Communications cable

The suited cable is different according to the combination of component. Please produce the cable of the following connecting wires when connecting with a Mitsubishi Electric Standard PLC Q series (QJ71C24N-R2).

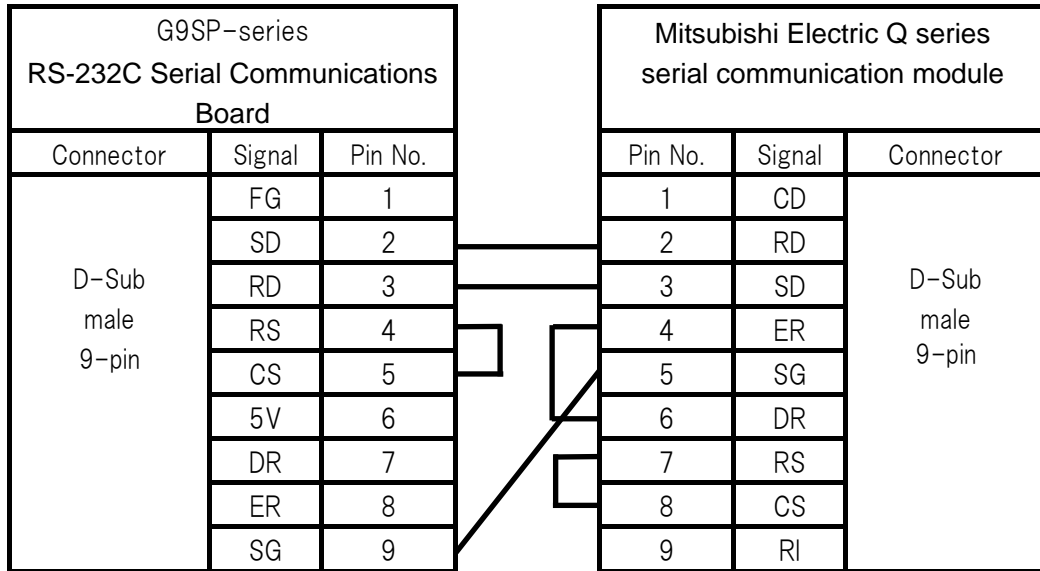

Sample Ladder Programming for Mitsubishi Electric PLC Q series

This section provides an example of programming to monitor Safety Input terminal data of a G9SP-series Controller from a Mitsubishi Electric Standard PLC Q series.

- RS-232C Serial Communications Sequence

The G9SP-series Controller returns a response to the command sent from the Standard PLC.

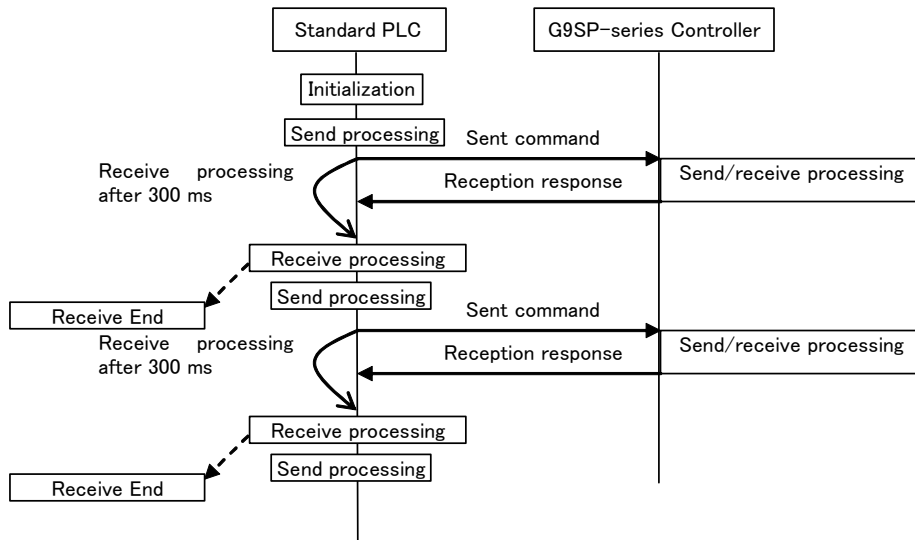

● Sample Ladder Programming

- From Initial Settings to Cyclic Send/Receive

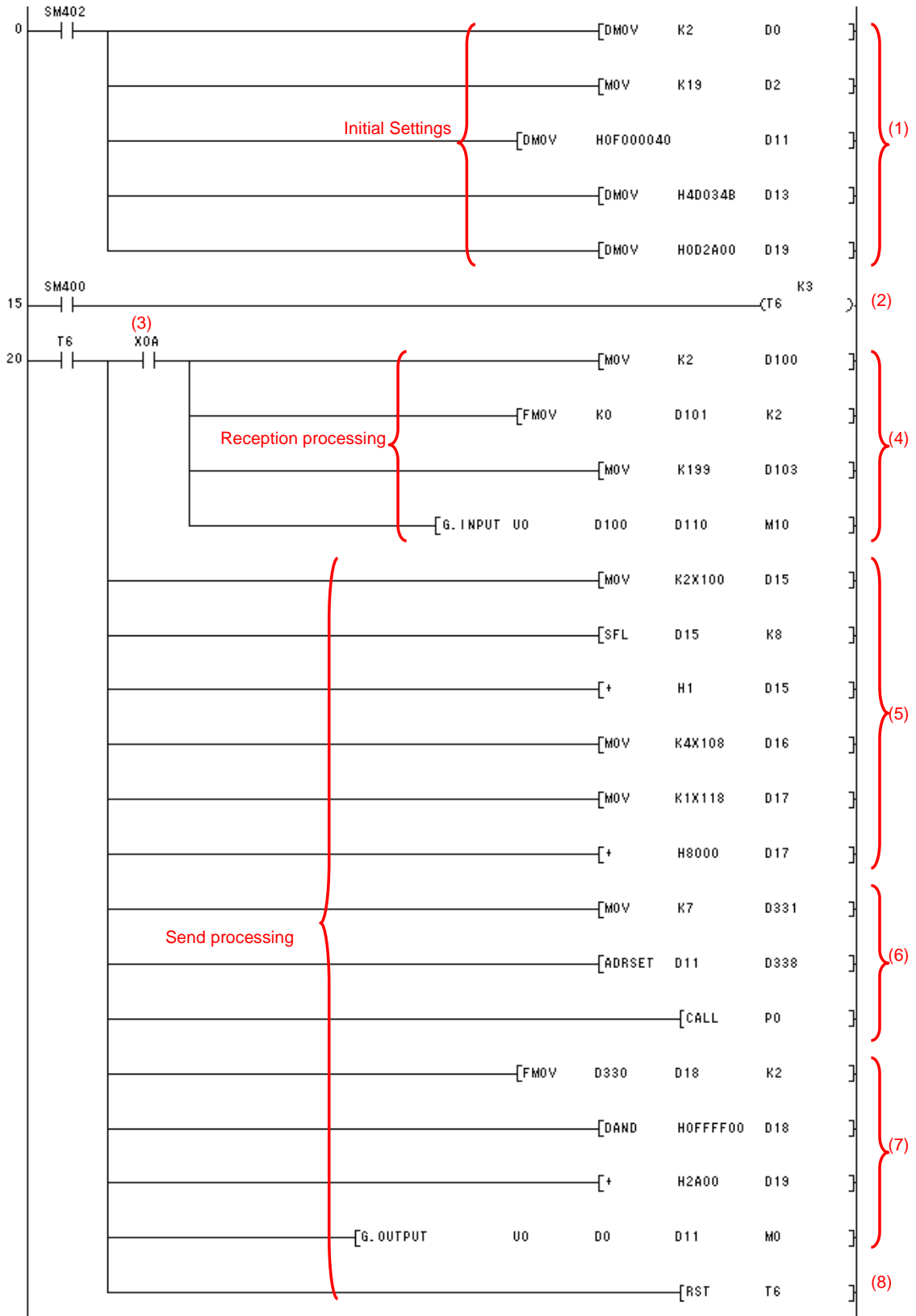

- Reception completion processing

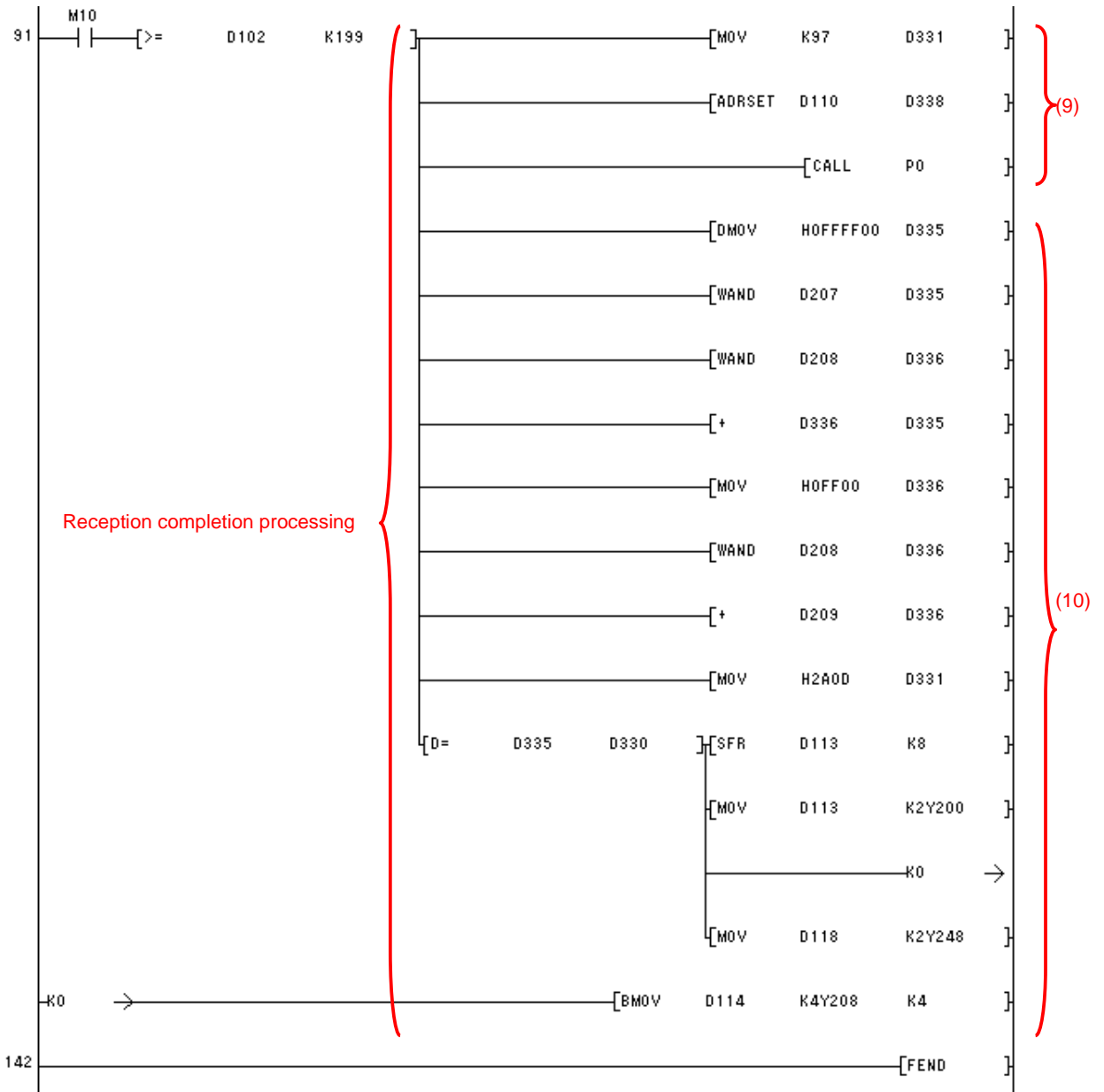

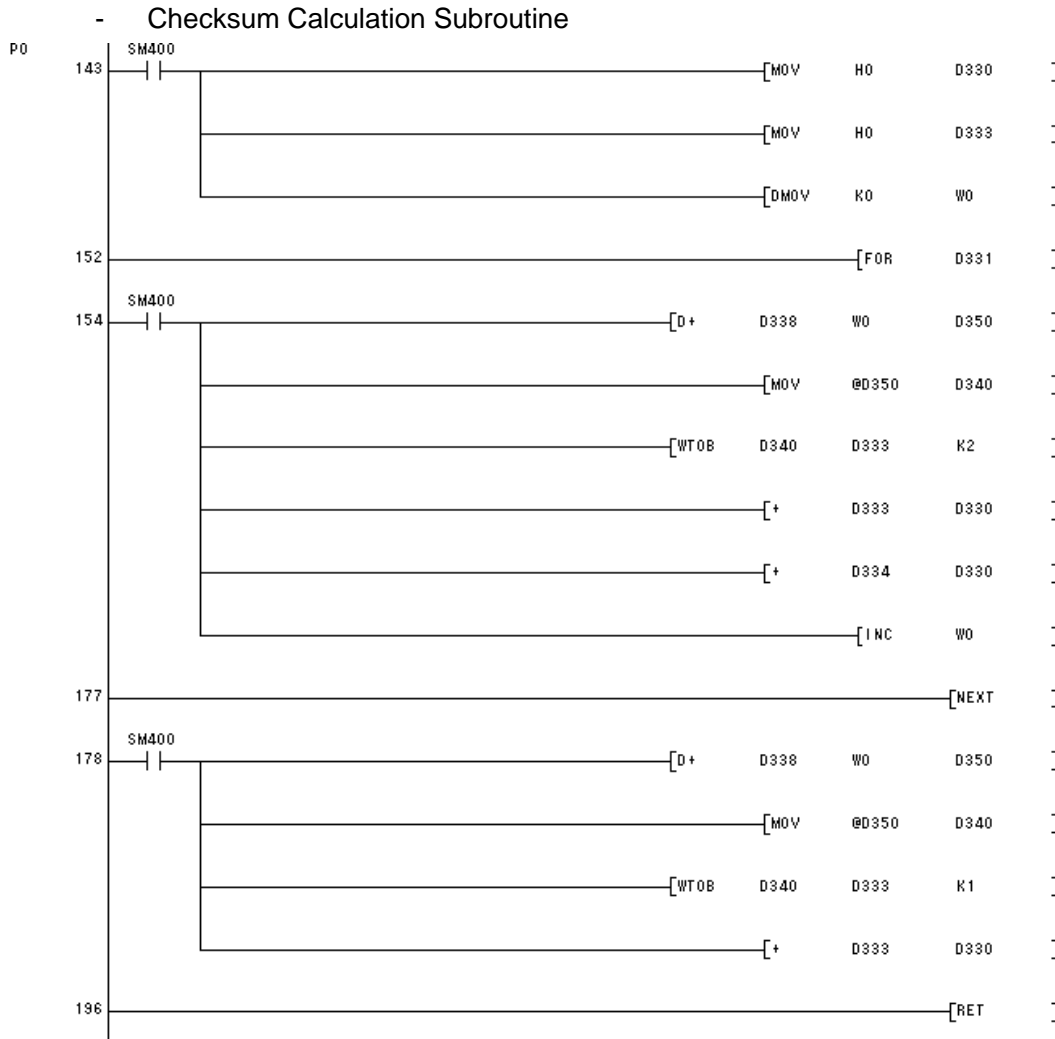

Step	Description
(1)	The fixed portion of the send command is set. This processing is performed once at startup.
(2)	A communications refresh timer of 300 ms is started. This performs the first sending after 300 ms.
(3)	Once 300 ms has elapsed, the RS-232C reception end bit (X0A) is checked, and receive processing is performed if data has been received. A send command from the Standard PLC is initially required, and so reception processing is performed after completing the first send.
(4)	To store the reception response in D100, the INPUT instruction is executed.
(5)	G9SP communications reception data is set to the send command from X 100 and echo back bit.
(6)	The send command is transferred to the RS-232C send port, which enables sending to the G9SP-series Controller.
(7)	The checksum and the end code are set to the transmission command. The send command is transferred to the RS-232C send port, which enables sending to the G9SP-series Controller.
(8)	The timer is restarted and the next receive processing is performed after 300 ms.
(9)	The checksum calculation subroutine given above is called, and the checksum of the reception response is calculated.
(10)	The checksum of the reception response and the end code are checked, and the G9SP Communications Transmission Data is copied to Y 200 and G9SP Safety Input Terminal Data is copied to Y 220.

2 - 2 - 3 Application Example 2(Connecting to the Mitsubishi Standard PLC FX Series.)

System Configuration

This section uses the following example to describe how to access a G9SP-series Controller by performing serial communications through a RS-232C Serial Communications Board (CP1W-CIF01) from a Siemens Standard PLC FX series.

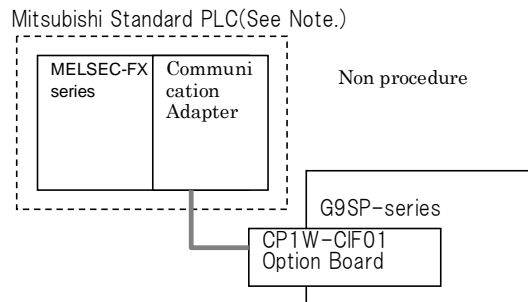

Note: This example uses the following Mitsubishi Electric Standard PLC.

Product	Model/Version
CPU Unit (Standard PLC)	FX3UC-32MT-LT
RS-232C Communication Adapter	FX3U-232AP
Support Software (for setup and creating ladder programs)	GX Developer Version 8.90U

G9SP-series Controller Settings

Settings are not required. Make the communications settings in the Mitsubishi Electric Standard PLC to match the serial communications specifications of the G9SP-series Controller.

Mitsubishi Electric PLC FX series Settings

Set RS-232C communication adapter CH1 as given below in the PLC parameter using the GX Developer.

- PLC parameter settings

Set RS-232C communication adapter CH2 as given below in the PLC parameter by selecting[Project data list]-[Parameter]-[PLC parameter]-[PLC System(2)].

Parameter	Description	Set value for this example
Protocol	Communication protocol	Non-procedural
Data length	Transmission setting	8bit
Parity		Even
Stop bit		1bit
Transmission Speed	Baud rate	9600
Header	Set the header.	Yes
H/W Type	Normally choose RS-232 or RS-485.	Regular/RS232C
Transmission control procedure	Choose format 1/format 4.	Form1 (without CR,LF)
Time out judge time	Set the time-out period.	30(300msec)

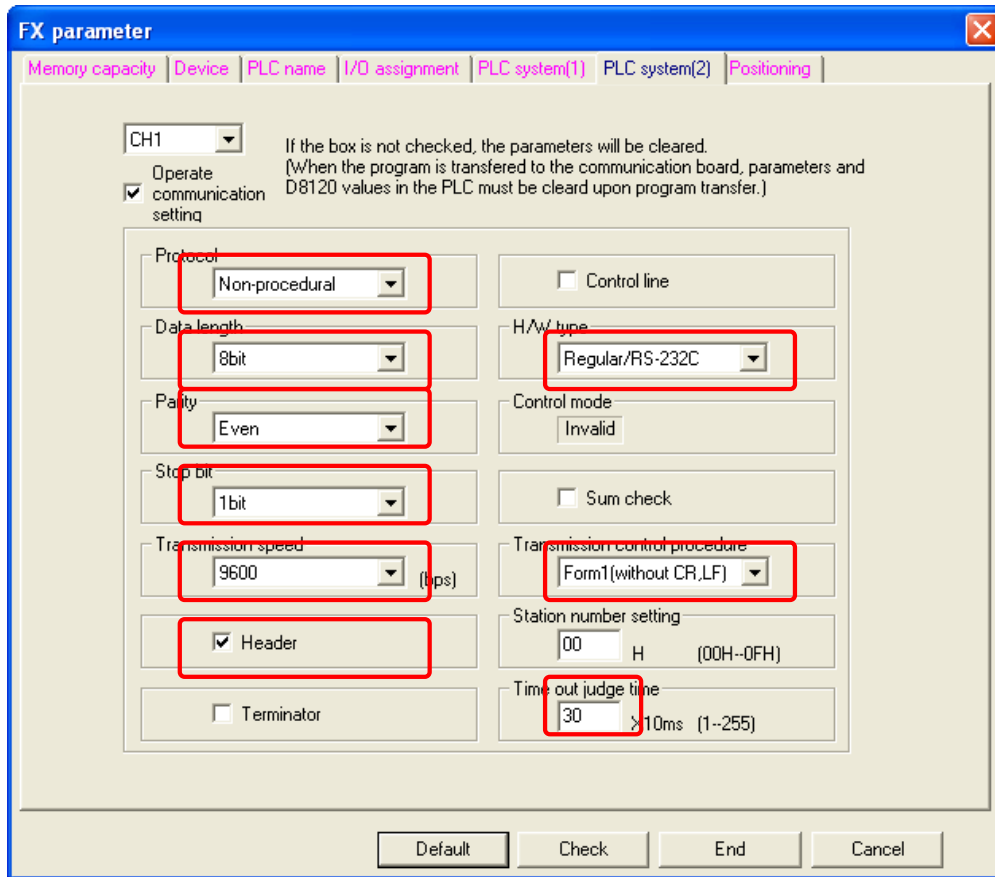

Communications cable

The suited cable is different according to the combination of component. Please produce the cable of the following connecting wires when connecting with a Mitsubishi Electric Standard PLC FX series.

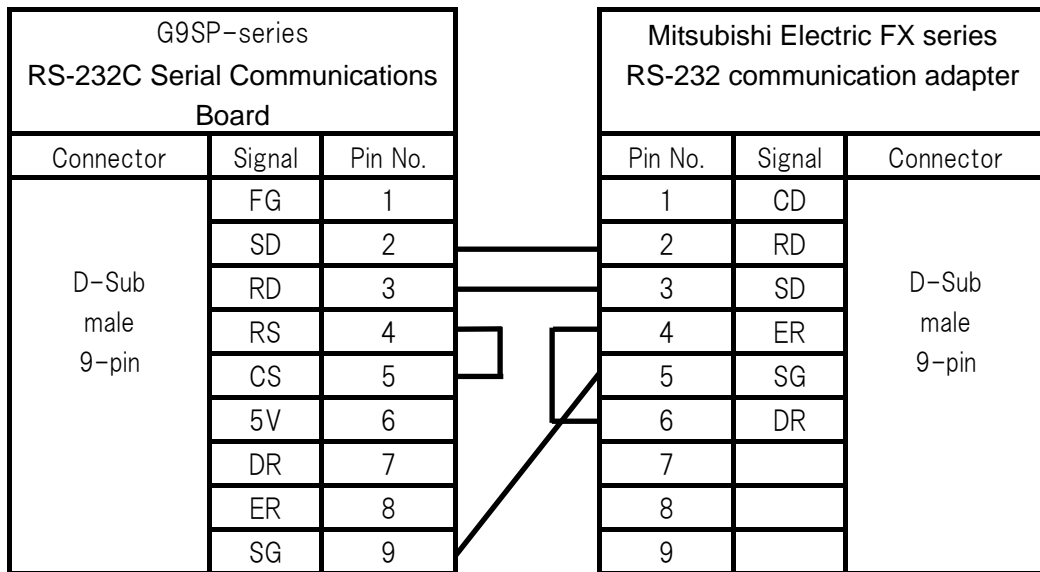

Sample Ladder Programming for Mitsubishi Electric PLC FX series

This section provides an example of programming to monitor Safety Input terminal data of a G9SP-series Controller from a Mitsubishi Electric Standard PLC FX series.

● RS-232C Serial Communications Sequence

The G9SP-series Controller returns a response to the command sent from the standard PLC.

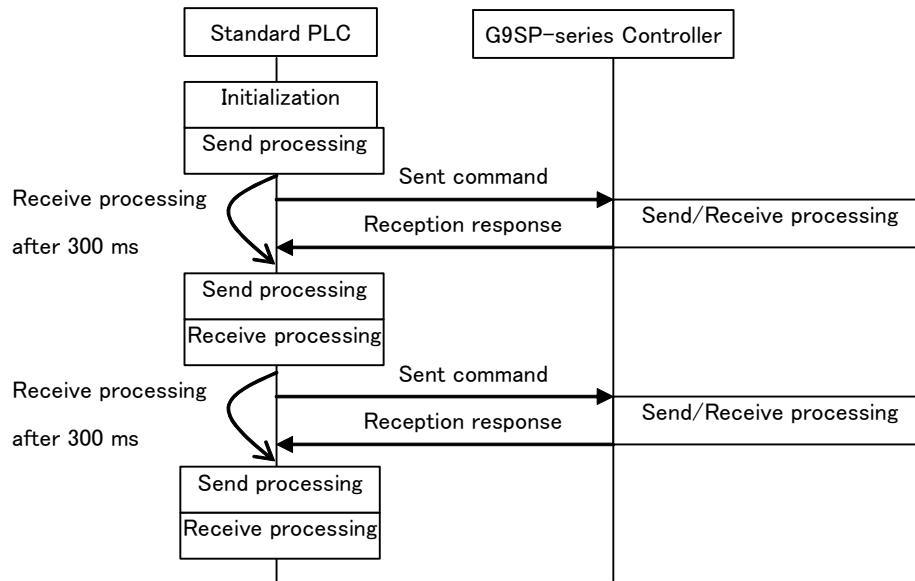

● Mitsubishi Electric Standard PLC FX series Memory Allocations

Start address	End address	Contents	Description
D100	D108	RS-232C send command	Data sent by the Standard PLC to the G9SP-series Controller
D200	D298	RS-232C reception response	Data received by the Standard PLC from the G9SP-series Controller
D330	D336	Checksum calculation work area	Work area for RS-232C communications. Used to calculate the check-sum
X100	X11F	G9SP communications reception data (written to G9SP-series Controller)	Data written to G9SP-series Controller from Standard PLC. Stored in the communications reception data of the G9SP-series Controller.
Y200	Y21F	G9SP communications transmission data (read from the G9SP-series Controller)	Communications data sent from the G9SP-series Controller is read.
Y220	Y24F	G9SP Safety Input terminal data (read from the G9SP-series Controller)	Safety Input terminal data of the G9SP-series Controller is read.

- G9SP Communications Reception Data

	15								8								7								0														
X100	bit	bit	bit	bit	bit	bit	bit	bit	bit	bit	bit	bit	bit	bit	bit	bit	bit	bit	bit	bit	bit	bit	bit	bit	bit	bit	bit	bit	bit	bit	bit	bit	bit	bit	bit	bit	bit	bit	bit
	15	14	13	12	11	10	09	08	07	06	05	04	03	02	01	00					31	30	29	28	27	26	25	24	23	22	21	20	19	18	17	16			
X110	bit	bit	bit	bit	bit	bit	bit	bit	bit	bit	bit	bit	bit	bit	bit	bit	bit	bit	bit	bit	bit	bit	bit	bit	bit	bit	bit	bit	bit	bit	bit	bit	bit	bit	bit	bit	bit	bit	bit
	31	30	29	28	27	26	25	24	23	22	21	20	19	18	17	16																							

- G9SP Communications Transmission Data

	15								8								7								0														
Y200	bit	bit	bit	bit	bit	bit	bit	bit	bit	bit	bit	bit	bit	bit	bit	bit	bit	bit	bit	bit	bit	bit	bit	bit	bit	bit	bit	bit	bit	bit	bit	bit	bit	bit	bit	bit	bit	bit	bit
	15	14	13	12	11	10	09	08	07	06	05	04	03	02	01	00					31	30	29	28	27	26	25	24	23	22	21	20	19	18	17	16			
Y210	bit	bit	bit	bit	bit	bit	bit	bit	bit	bit	bit	bit	bit	bit	bit	bit	bit	bit	bit	bit	bit	bit	bit	bit	bit	bit	bit	bit	bit	bit	bit	bit	bit	bit	bit	bit	bit	bit	bit
	31	30	29	28	27	26	25	24	23	22	21	20	19	18	17	16																							

- G9SP Safety Input Terminal Data

	15								8								7								0														
Y220	Si	Si	Si	Si	Si	Si	Si	Si	Si	Si	Si	Si	Si	Si	Si	Si	Si	Si	Si	Si	Si	Si	Si	Si	Si	Si	Si	Si	Si	Si	Si	Si	Si	Si	Si	Si	Si	Si	Si
	15	14	13	12	11	10	09	08	07	06	05	04	03	02	01	00																							
Y230	Reserved																Si	Si	Si	Si																			
																	19	18	17	16																			
Y240	Reserved																																						

● Sample Ladder Programming

- From Initial Settings to Cyclic Send/Receive

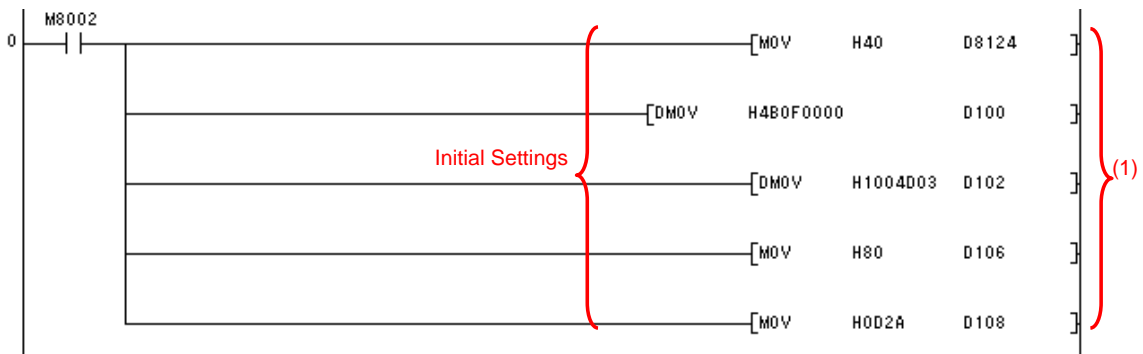

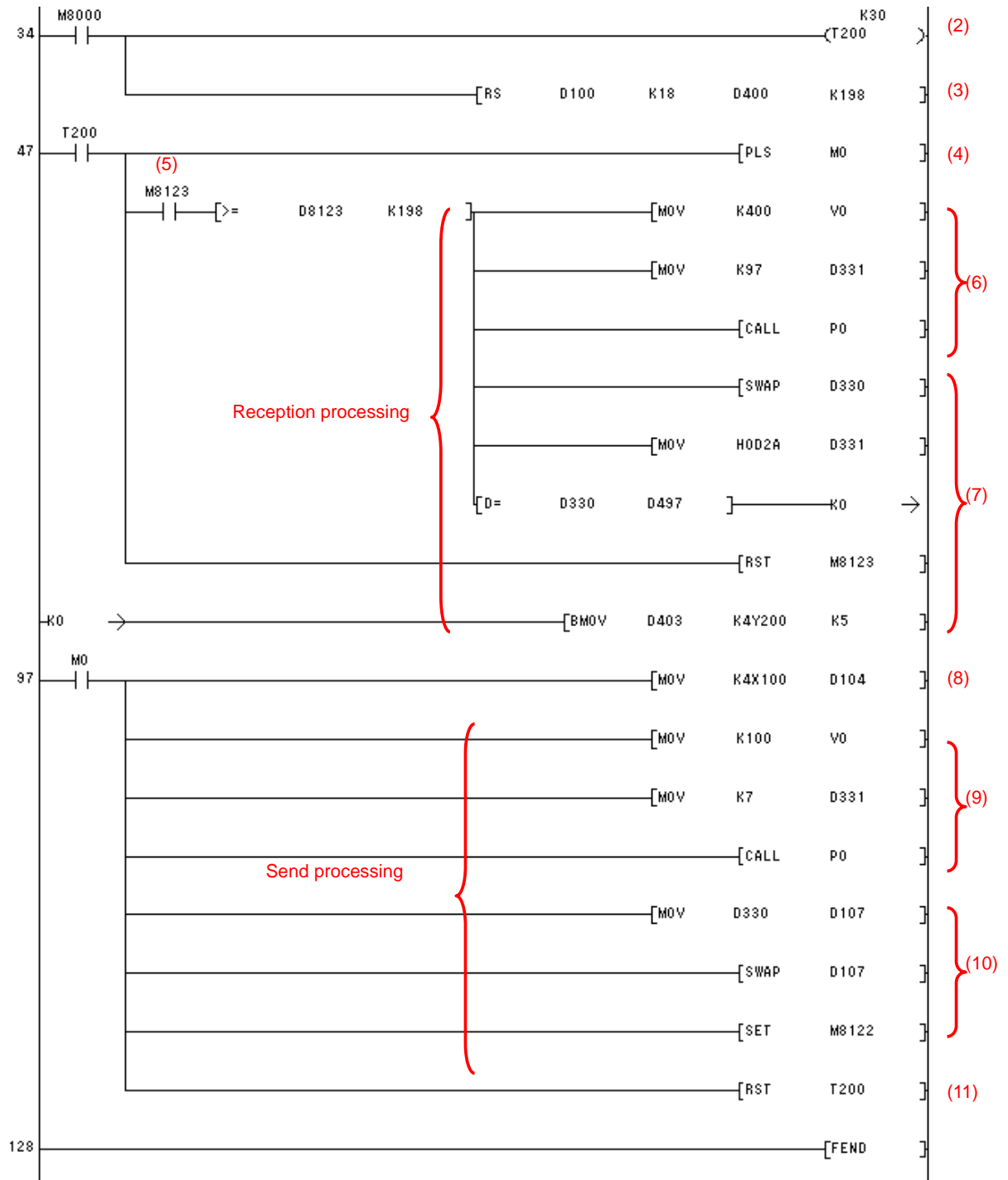

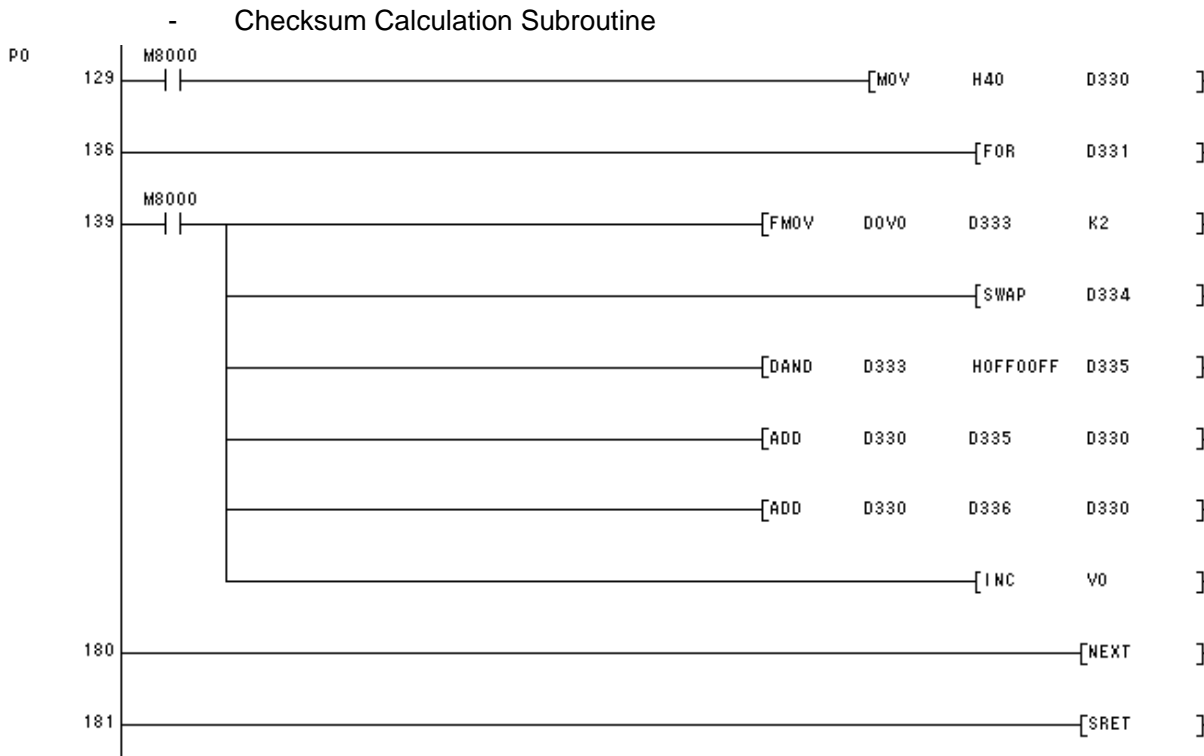

Step	Description
(1)	The fixed portion of the send command is set. This processing is performed once at startup.
(2)	A communications refresh timer of 300 ms is started. This performs the first sending after 300 ms.
(3)	To execute the sending and receiving of the RS232C port, the RS instruction is executed.
(4)	Once 300 ms has elapsed, to execute the transmission processing, the pulse is set to M0.
(5)	Once 300 ms has elapsed, the RS-232C reception end bit (M8123) is checked, and receive processing is performed if data has been received. A send command from the Standard PLC is initially required, and so reception processing is performed after completing the first send.
(6)	The checksum calculation subroutine given above is called, and the checksum of the reception response is calculated.
(7)	The checksum of the reception response and the end code are checked, and the G9SP Communications Transmission Data is copied to Y200 and G9SP Safety Input Terminal Data is copied to Y220.
(8)	G9SP communications reception data is set to the send command from X 100.
(9)	The checksum calculation subroutine given above is called, and the checksum of the transmission command is calculated.
(10)	The checksum are set to the transmission command. The send command is transferred to the RS-232C send port, which enables sending to the G9SP-series Controller.
(11)	The timer is restarted and the next receive processing is performed after 300 ms.

2 - 3 Ethernet Communications

This section provides a description and example of connection to a Mitsubishi Electric Standard PLC. The FINS/UDP Protocol are available for connection with a Mitsubishi Electric Standard PLC.

2 - 3 - 1 Communications Format

Refer to Section 7 Communications with a Standard PLC Using an Option Board of the G9SP Series Safety Controller Operation Manual (Cat. No. Z922).

2 - 3 - 2 Application Example

System Configuration

This section uses the following example to describe how to access the G9SP-series Controller by performing Ethernet communications through a Ethernet Communications Board (CP1W-CIF41) from a Mitsubishi Electric Standard PLC Q series.

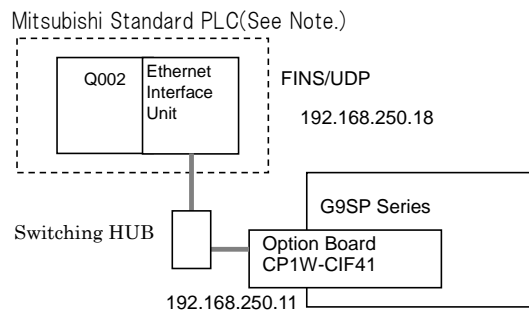

Note: This example uses the following Mitsubishi Electric Standard PLC.

Product	Model/Version
CPU Unit (Standard PLC)	Q02HCPU
Ethernet Interface Unit	QJ71E71-100
Support Software (for setup and creating ladder programs)	GX Developer Version 8.90U

G9SP-series Controller Settings

Make the settings for TCP/IP in the system settings of the G9SP Configurator. These settings are set in the G9SP-series Controller and Ethernet Option Board when the configuration data is downloaded.

Parameter	Description	Set value for this example
IP address	IP address of Ethernet Option Board. Default value: 192.168.250.1	192.168.250.11
Subnet mask	Subnet mask of Ethernet Option Board. Default value: 255.255.255.0	No change is required.
Default gateway	Set the IP address of the default gateway. Default value: 0.0.0.0 (IP routing not supported)	No change is required.
FINS node address	Set the FINS node address of the Ethernet Option Board. If automatic setting is specified, a value that matches the rightmost byte of the IP address is stored. Default value: Automatic (matching the rightmost byte of the IP address) Setting range: 1 to 254	No change is required.
FINS/UDP port	Specify the UDP port number that is specified in the FINS communications service. The UDP port number is a number used by UDP to identify the application layer (here, the FINS communications service). Default value: 0 (9600) Setting range: 0 to 65535. When set to 0, the FINS/UDP port number is 9600.	No change is required.
IP address table	Set the table that defines correspondence between the FINS node address and IP address at the Standard PLC. Set the IP address table when IP routing is used.	No change is required.

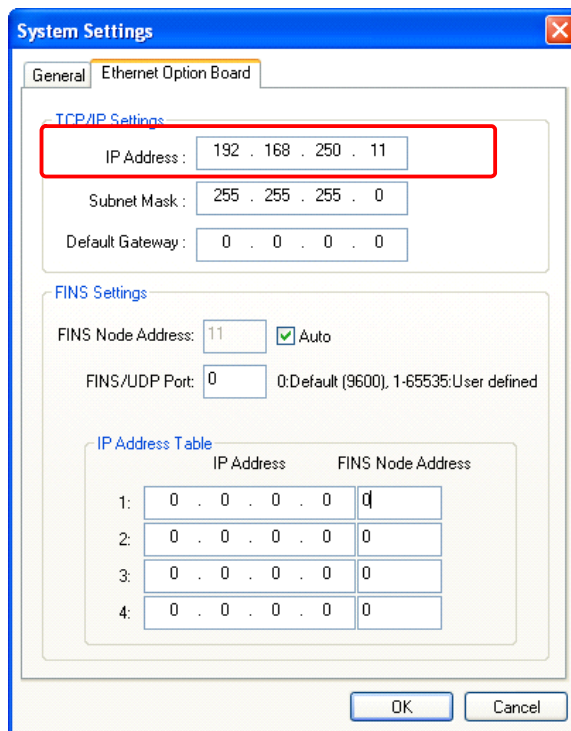

Mitsubishi Electric PLC Q series Settings

Set the Ethernet Interface Unit as given below in the network parameter of the Ethernet port using the GX Developer.

- Network parameters : Setting the number of Ethernet/CC IE/MELSECNET cards
Set the setting the number of Ethernet/CC IE/MELSECNET cards by selecting [Project data list]-[Parameter] – [Network param] – [Ethernet/CC IE/MELSECNET].

Parameter	Description	Set value for this example
Network type	Select installed unit	Ethernet
Starting I/O No.	Set a top address of unit	0000
Network No.	Set a network number of unit	1
Group No.	Set a group number of unit	1
Station No.	Select a station number of unit	1
Mode	Select a operation mode of unit	On line

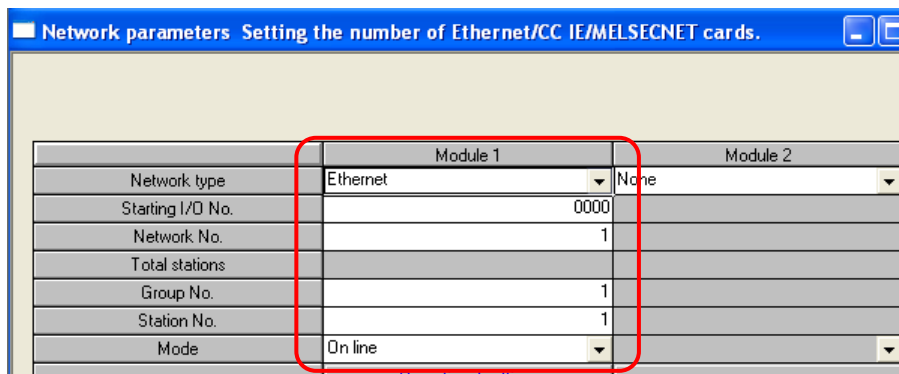

- Operation Settings

Set the setting the Ethernet operations by selecting [Project data list]-[Parameter] – [Network param] – [Ethernet/CC IE/MELSECNET] – [Operation Settings].

Parameter	Description	Set value for this example
IP Address	IP address of QJ71E71-100.	192.168.250.18

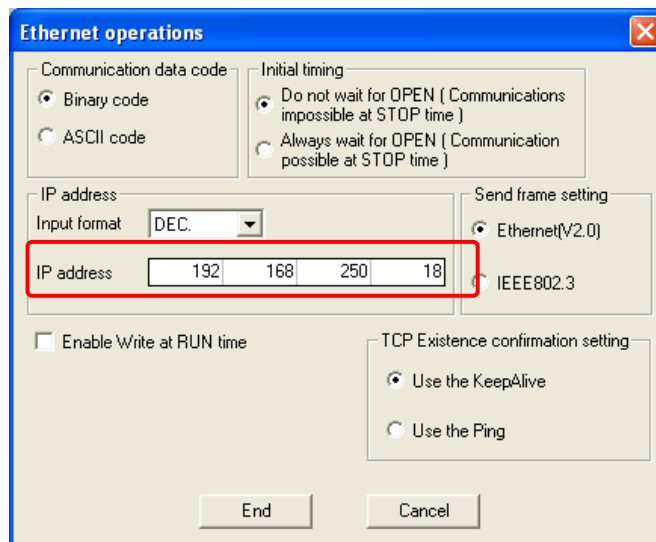

● Open Settings

Set the setting the Ethernet operations by selecting [Project data list]-[Parameter] – [Network param] – [Ethernet/CC IE/MELSECNET] – [Open Settings].

Parameter	Description	Set value for this example
Protocol	Set a communication protocol	UDP
Fixed buffer communication procedure	Select a communication procedure using fixed buffer	No procedure
Pairing open	Select a pairing open	Enable
Existence confirmation	Select an existence confirmation	Confirm
Host station Port No.	Set a port number of the host station	2580
Transmission target device IP address	Set an IP address of the transmission target device	192.168.250.11
Transmission target device Port No.	Set a port number of the transmission target device	2580

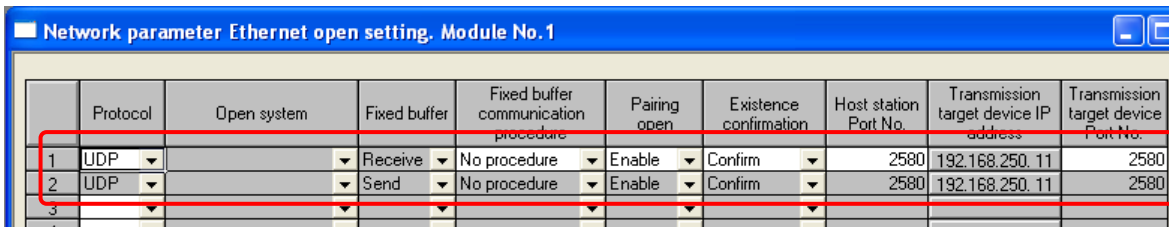

Communication cable

The Ethernet Option Board is connected with a switching HUBs by using the twisted-pair cable that applies the modular connector of the RJ45 form to both ends. Either of category 3, 4, 5 or 5e UTP cable (Unshield twist pair cable), or STP cable (Shield twist pair cable) is available.

Sample Ladder Programming for Mitsubishi Electric PLC Q series

This section provides an example of programming to monitor Safety Input terminal data of a G9SP-series Controller from a Mitsubishi Electric Standard PLC Q series.

● Ethernet Communications Sequence

The G9SP-series Controller returns a response to the command sent from the Standard PLC.

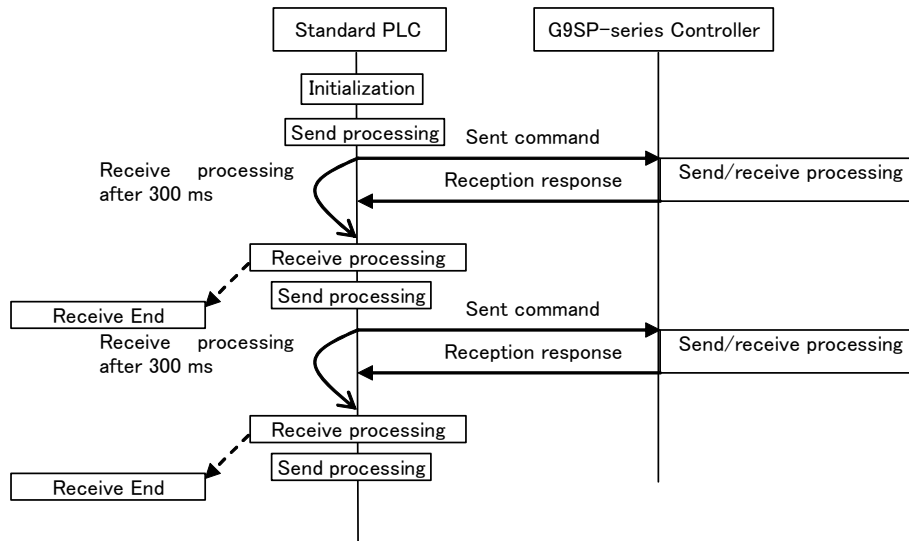

● Mitsubishi Electric Standard PLC Q series Memory Allocations

Start address	End address	Contents	Description
D300	D312	Ethernet send command	Data sent by the Standard PLC to the G9SP-series Controller.
D500	D603	Ethernet reception response	Data received by the Standard PLC from the G9SP-series Controller.
D3000	-	BUFSND instruction control data	Control data for the BUFSND instruction is stored.
D5000	-	BUFRCV instruction control data	Control data for the BUFRCV instruction is stored.
X100	X11F	G9SP communications reception data (written to G9SP-series Controller)	Data written to G9SP-series Controller from Standard PLC. Stored in the communications reception data of the G9SP-series Controller.
Y200	Y21F	G9SP communications transmission data (read from the G9SP-series Controller)	Communications data sent from the G9SP-series Controller is read.
Y220	Y24F	G9SP Safety Input terminal data (read from the G9SP-series Controller)	Safety Input terminal data of the G9SP-series Controller is read.

- G9SP Communications Reception Data

	15								8 7								0																			
X100	bit	bit	bit	bit	bit	bit	bit	bit	bit	bit	bit	bit	bit	bit	bit	bit	bit	bit	bit	bit	bit	bit	bit	bit	bit	bit	bit	bit	bit							
	15	14	13	12	11	10	09	08	07	06	05	04	03	02	01	00					31	30	29	28	27	26	25	24	23	22	21	20	19	18	17	16
X110	bit	bit	bit	bit	bit	bit	bit	bit	bit	bit	bit	bit	bit	bit	bit	bit	bit	bit	bit	bit	bit	bit	bit	bit	bit	bit	bit	bit	bit							
	31	30	29	28	27	26	25	24	23	22	21	20	19	18	17	16																				

- G9SP Communications Transmission Data

	15								8 7								0																			
Y200	bit	bit	bit	bit	bit	bit	bit	bit	bit	bit	bit	bit	bit	bit	bit	bit	bit	bit	bit	bit	bit	bit	bit	bit	bit	bit	bit	bit								
	15	14	13	12	11	10	09	08	07	06	05	04	03	02	01	00					31	30	29	28	27	26	25	24	23	22	21	20	19	18	17	16
Y210	bit	bit	bit	bit	bit	bit	bit	bit	bit	bit	bit	bit	bit	bit	bit	bit	bit	bit	bit	bit	bit	bit	bit	bit	bit	bit	bit	bit								
	31	30	29	28	27	26	25	24	23	22	21	20	19	18	17	16																				

- G9SP Safety Input Terminal Data

	15								8 7								0																			
Y220	Si	Si	Si	Si	Si	Si	Si	Si	Si	Si	Si	Si	Si	Si	Si	Si	Si	Si	Si	Si	Si	Si	Si	Si	Si	Si	Si	Si								
	15	14	13	12	11	10	09	08	07	06	05	04	03	02	01	00					19	18	17	16												
Y230	Reserved												Si	Si	Si	Si																				
													19	18	17	16																				
Y240	Reserved																																			

● Sample Ladder Programming

- From Initial Settings to Cyclic Send/Receive

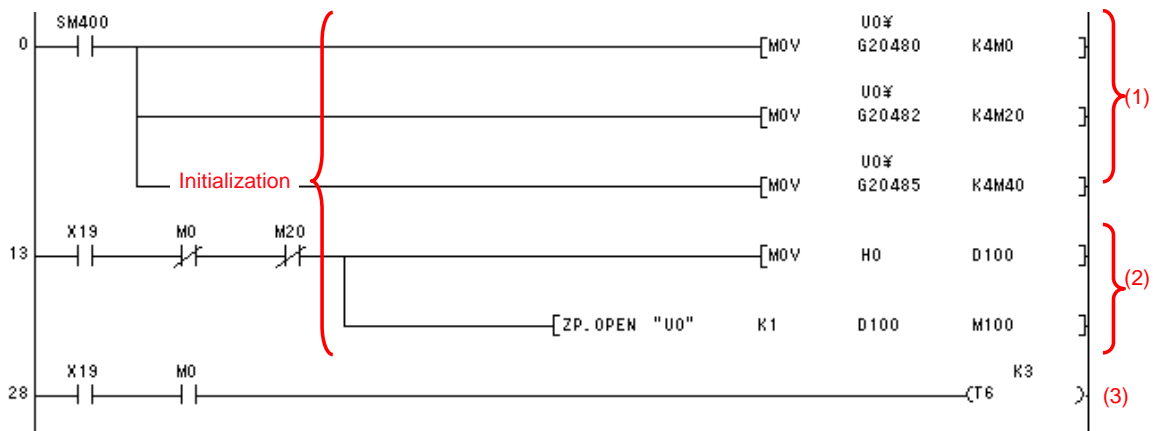

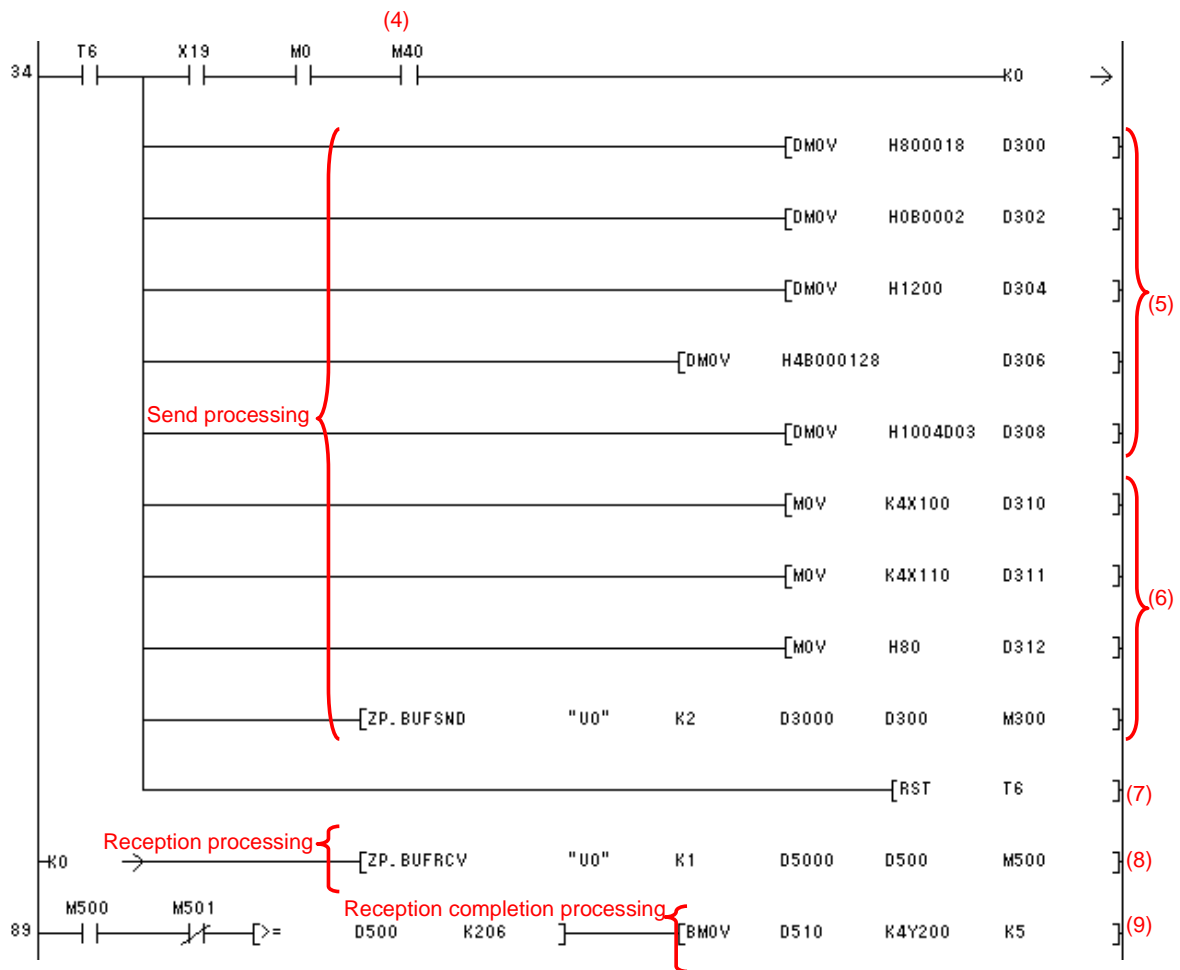

Step	Description
(1)	The fixed portion of the connection process is set. This processing is performed once at startup.
(2)	The connection is open after the initialization process is completed.
(3)	A communications refresh timer of 300 ms is started. This performs the first sending after 300 ms.
(4)	Once 300 ms has elapsed, the reception completion bit (M40) is checked, and receive processing is performed if data has been received. A send command from the Standard PLC is initially required, and so reception processing is performed after completing the first send.
(5)	Set the FINS data to the sending command.
(6)	Set the "G9SP communication reception data" to X100 of sending command and set the "Echo back bit" and transfer to Ethernet port. By this flow, the sending command is transferred to the G9SP series.
(7)	The timer is restarted and the next receive processing is performed after 300 ms.
(8)	The ZB.BUFRCV instruction is executed because the reception response is stored to D500.
(9)	The checksum of the reception response and the end code are checked, and the G9SP Communications Transmission Data is copied to Y200 and G9SP Safety Input Terminal Data is copied to Y220.

3

Connecting to Siemens PLCs

This section describes how to perform communications with a Siemens Standard PLC through an RS-232C Option Board or Ethernet Option Board.

3 - 1	Functionality	3-2
3 - 2	RS-232C Serial Communications.....	3-3
3 - 2 - 1	Communications Format	3-3
3 - 2 - 2	Application Example	3-3
3 - 3	Ethernet Communications.....	3-11
3 - 3 - 1	Communications Format	3-11
3 - 3 - 2	Application Example	3-11

3 - 1 Functionality

Refer to Section 7 Communications with a Standard PLC Using an Option Board of the G9SP Series Safety Controller Operation Manual (Cat. No. Z922).

3 - 2 RS-232C Serial Communications

This section provides a description and example of connection to a Siemens Standard PLC. Freeport protocol communications are used for connection with a Siemens Standard PLC.

3 - 2 - 1 Communications Format

Refer to Section 7 Communications with a Standard PLC Using an Option Board of the G9SP Series Safety Controller Operation Manual (Cat. No. Z922).

3 - 2 - 2 Application Example

System Configuration

This section uses the following example to describe how to access a G9SP-series Controller by performing serial communications through a RS-232C Serial Communications Board (CP1W-CIF01) from a Siemens Standard PLC.

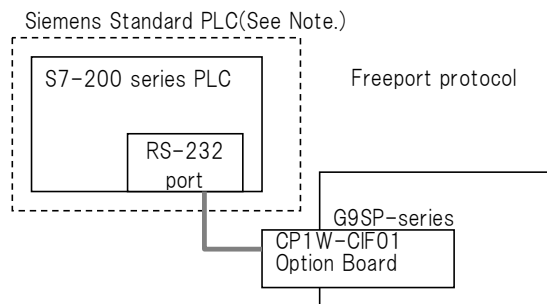

Note: This example uses the following Siemens Standard PLC.

Product	Model/version
CPU Unit (Standard PLC)	S7-200 CPU 224XP
Support Software (for setup and creating ladder programs)	STEP 7-Micro/WIN V4.0.5.08

G9SP-series Controller Settings

Settings are not required. Make the communications settings in the Siemens Standard PLC to match the serial communications specifications of the G9SP-series Controller.

Siemens PLC Settings

Set serial port 1 as given below in the Ladder using the STEP 7-Micro/WIN.

Parameter	Description	Set value for this example																
Freeport Control Registers	Control Freeport communication for serial port	Please set SMB130 to \$49. SMB130 Bit Format MSB LSB <table border="1" style="width: 100%; text-align: center;"> <tr> <td>7</td><td>6</td><td>5</td><td>4</td><td>3</td><td>2</td><td>1</td><td>0</td> </tr> <tr> <td>P</td><td>D</td><td colspan="3">B</td><td colspan="3">M</td> </tr> </table> P:Parity(0 1=Even parity) D:Data bits(0=8 data bits per character) B:Baud rate(0 1 0=9600bps) M:Protocol(0 1=Freeport protocol)	7	6	5	4	3	2	1	0	P	D	B			M		
7	6	5	4	3	2	1	0											
P	D	B			M													

Communications cable

The suited cable is different according to the combination of component. Please use the RS-232/PPI Multi-Master cable when connecting with RS-232C port of a Siemens Standard PLC.

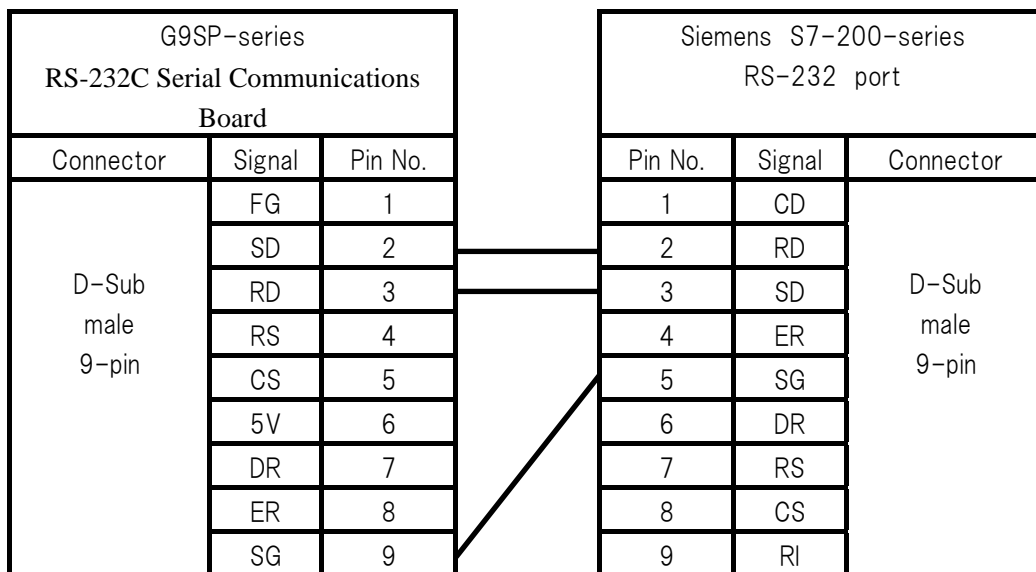

Sample Ladder Programming for Siemens PLC

This section provides an example of programming to monitor Safety Input terminal data of a G9SP-series Controller from a Siemens Standard PLC.

- RS-232C Serial Communications Sequence

The G9SP-series Controller returns a response to the command sent from the Standard PLC.

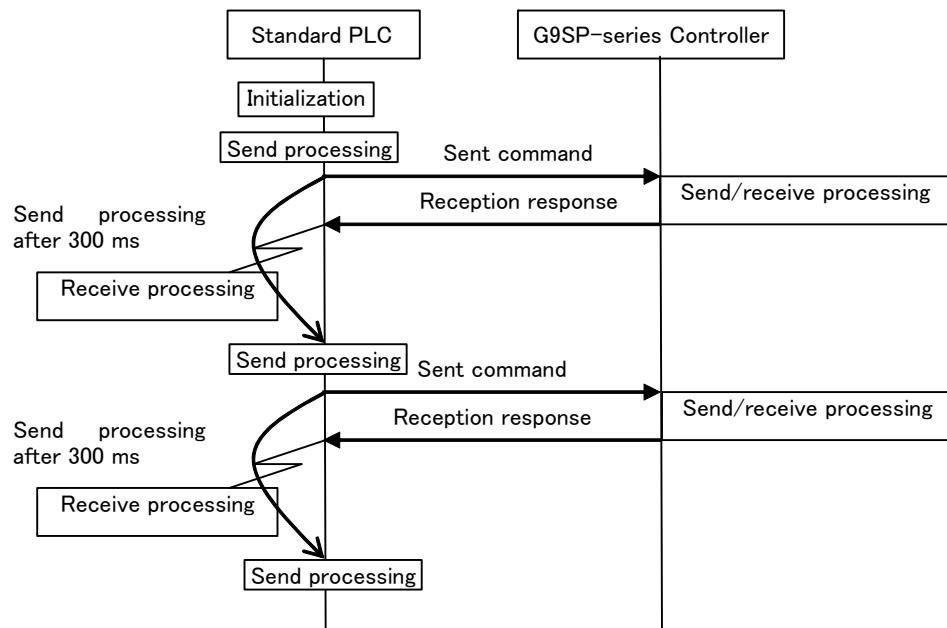

- Sample Ladder Programming
 - Initial Settings(MAIN)

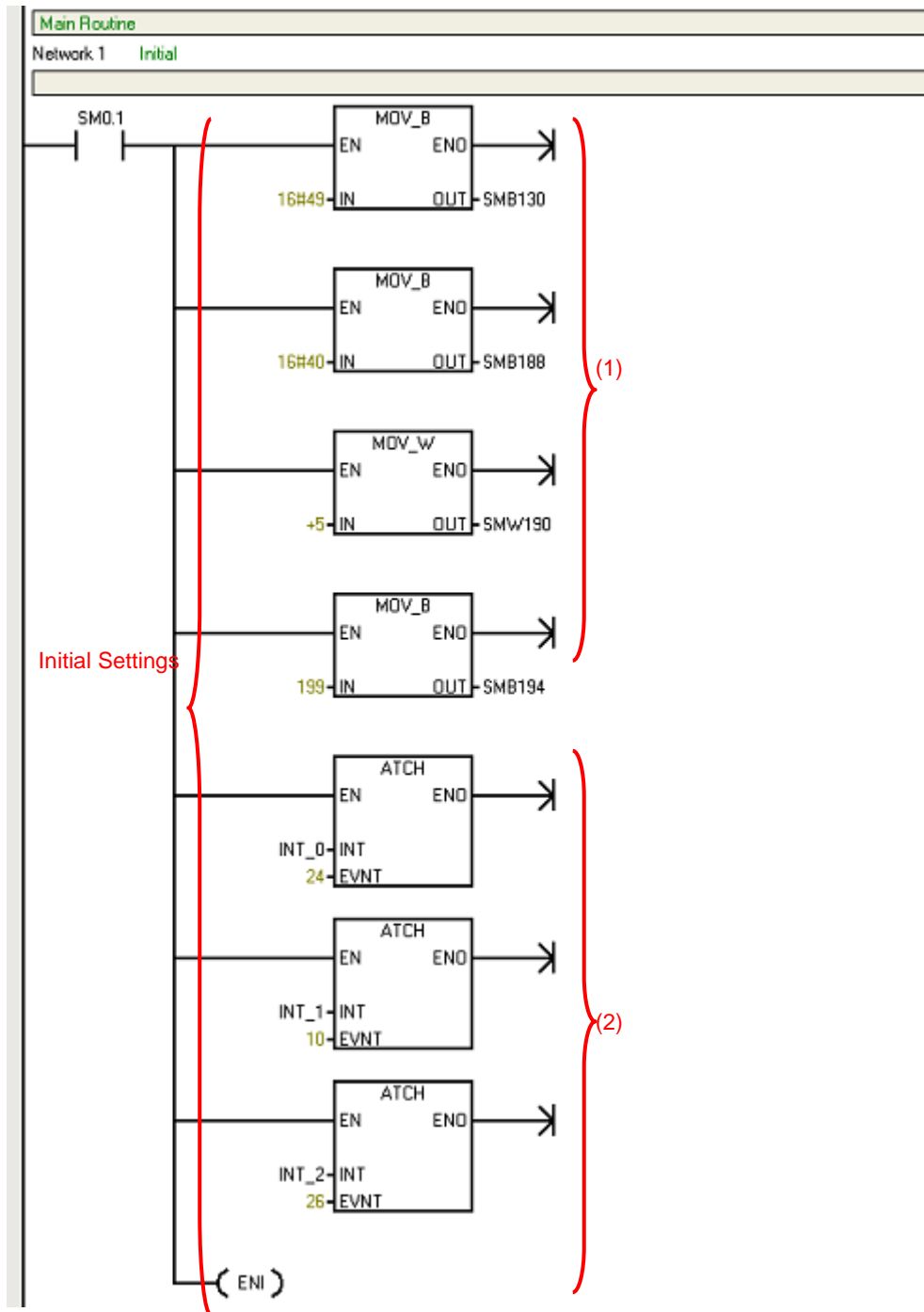

- Send processing(INT_1)

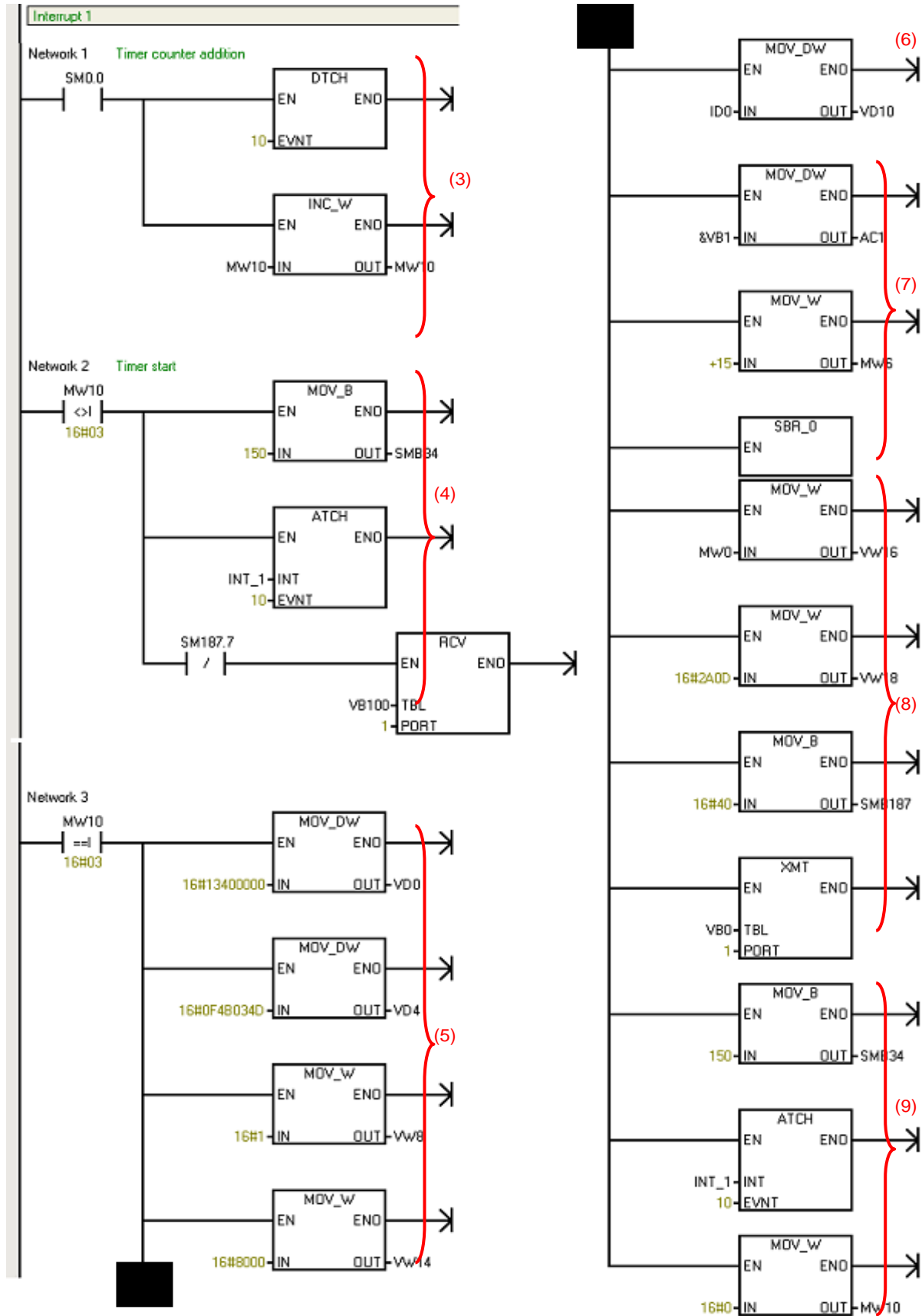

- Reception processing(INT_1)

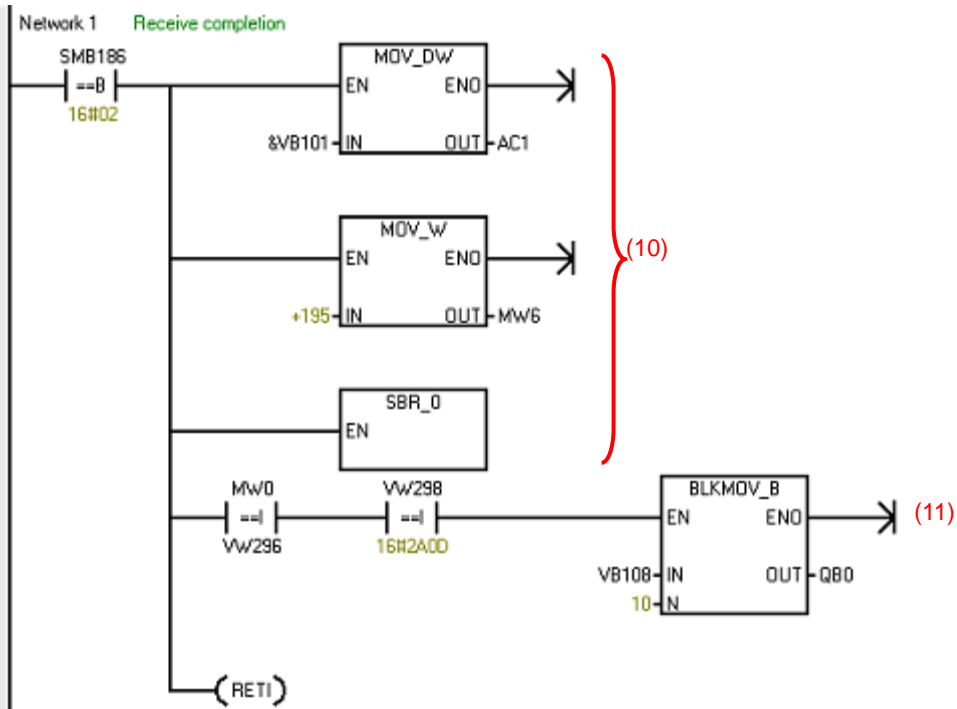

- Send end processing(INT_2)

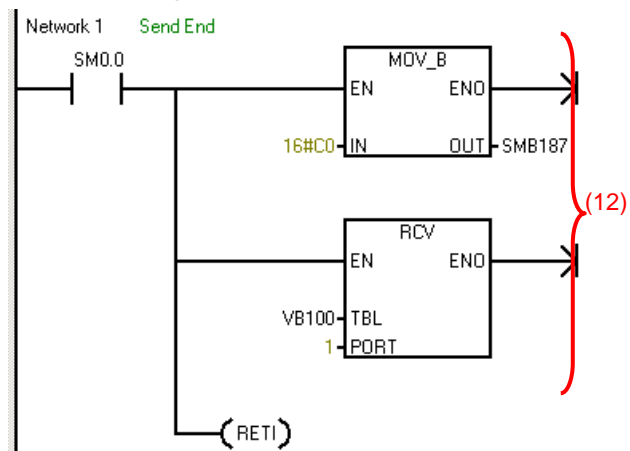

- Checksum Calculation Subroutine

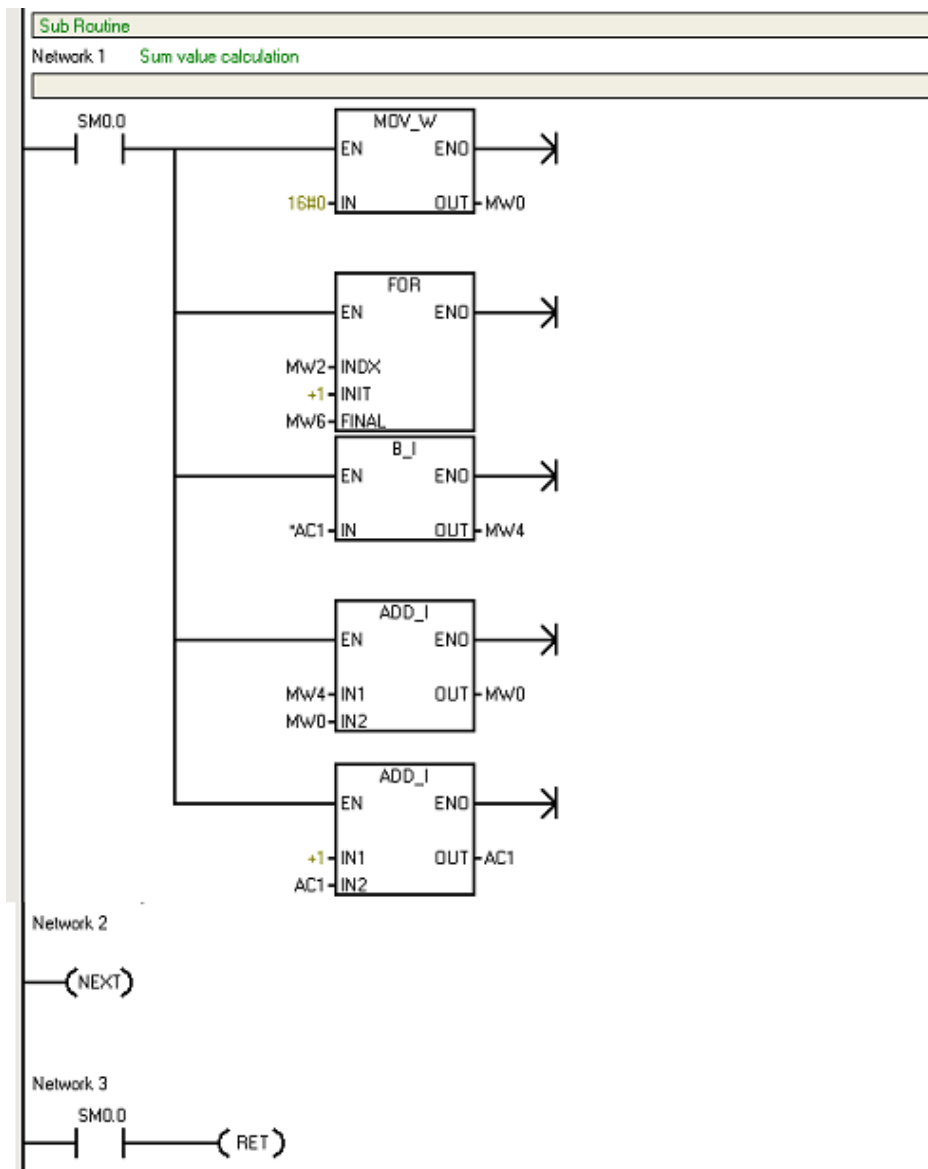

Step	Description
(1)	Control Freeport communication for port1 This processing is performed once at startup.
(2)	Enables the 150ms-timer event, receive complete event and send complete even. This processing is performed once at startup.
(3)	Once 100 ms has elapsed,to process each 300ms the counter is added
(4)	Once 300 ms has elapsed, enables receive complete event.
(5)	Once 300 ms has elapsed, the fixed portion of the send command is set.
(6)	G9SP communications reception data is set to the send command from I 0.
(7)	The checksum calculation subroutine given above is called, and the checksum of the send command is calculated.
(8)	The checksum and the end code are set to the transmission command.The send command is transferred to the RS-232C send port, which enables sending to the G9SP-series Controller.
(9)	The timer is restarted and the next send processing is performed after 300 ms.
(10)	The checksum calculation subroutine given above is called, and the checksum of the reception response is calculated.
(11)	The checksum of the reception response and the end code are checked, and the G9SP Communications Transmission Data is copied to Q 0 and Q 3 and G9SP Safety Input Terminal Data is copied to Q 4 to Q 9.
(12)	After the transmission is completed, the reception interruption is enabled.

3 - 3 Ethernet Communications

This section provides a description and example of connection to a Siemens Standard PLC. Connection can be performed to an Siemens Standard PLC using the FINS/UDP protocol.

Note: Only CP1W-CIF41 Ethernet Option Boards with unit version 2.0 or later can be used. If another Option Board is used, the G9SP-series Controller will detect an Un-supported Option Board Error (the MS indicator will flash red).

3 - 3 - 1 Communications Format

Refer to Section 7 Communications with a Standard PLC Using an Option Board of the G9SP Series Safety Controller Operation Manual (Cat. No. Z922).

3 - 3 - 2 Application Example

System Configuration

This section uses the following example to describe how to access the G9SP-series Controller from a Standard PLC by performing Ethernet communications through an Ethernet Communications Board (CP1W-CIF41).

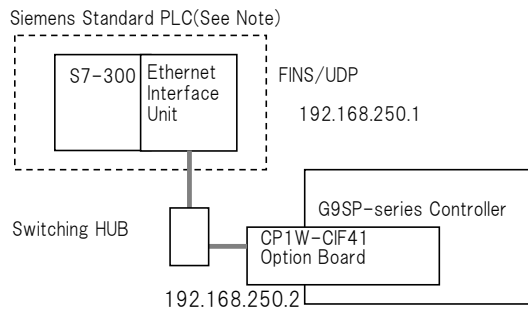

Note: This example uses the following Siemens Standard PLC.

Product	Model/version
CPU Unit (Standard PLC)	S7-300 CPU315-2 DP
Ethernet Interface Unit	CP343-1
Support Software (for setup and creating ladder/Function Block programs)	STEP 7 V5.3+SP3

G9SP-series Controller Settings

Make the settings for TCP/IP in the system settings of the G9SP Configurator. These settings are set in the G9SP-series Controller and Ethernet Option Board when the configuration data is downloaded.

Parameter	Description	Set value for this example
IP address	IP address of Ethernet Option Board. Default value: 192.168.250.1	192.168.250.2
Subnet mask	Subnet mask of Ethernet Option Board. Default value: 255.255.255.0	No change is required.
Default gateway	Set the IP address of the default gateway. Default value: 0.0.0.0 (IP routing not supported)	No change is required.
FINS node address	Set the FINS node address of the Ethernet Option Board. If automatic setting is specified, a value that matches the rightmost byte of the IP address is stored. Default value: Automatic (matching the rightmost byte of the IP address) Setting range: 1 to 254	No change is required.
FINS/UDP port	Specify the UDP port number that is specified in the FINS communications service. The UDP port number is a number used by UDP to identify the application layer (here, the FINS communications service). Default value: 0 (9600) Setting range: 0 to 65535. When set to 0, the FINS/UDP port number is 9600.	No change is required.
IP address table	Set the table that defines correspondence between the FINS node address and IP address at the Standard PLC. Set the IP address table when IP routing is used.	No change is required.

The screenshot shows the 'System Settings' dialog box with the 'Ethernet Option Board' tab selected. The 'TCP/IP Settings' section has the IP Address field highlighted with a red box, showing '192 . 168 . 250 . 2'. The Subnet Mask is '255 . 255 . 255 . 0' and the Default Gateway is '0 . 0 . 0 . 0'. The 'FINS Settings' section shows the FINS Node Address as '2' with the 'Auto' checkbox checked, and the FINS/UDP Port as '0'. The 'IP Address Table' section contains a table with 4 rows and 2 columns: IP Address and FINS Node Address. All values in the table are '0'.

	IP Address	FINS Node Address
1:	0 . 0 . 0 . 0	0
2:	0 . 0 . 0 . 0	0
3:	0 . 0 . 0 . 0	0
4:	0 . 0 . 0 . 0	0

Siemens PLC Settings

Set the Ethernet port as shown below in the Hardware Configuration using the STEP7.

- Ethernet Interface unit settings

Set Ethernet interface unit as given below in the H/W Config by selecting [General] - [Properties...].

Parameter	Description	Set value for this example
IP address	IP address of the CP343-1	192.168.250.1
Subnet mask	Subnet mask of the CP343-1	255.255.255.0

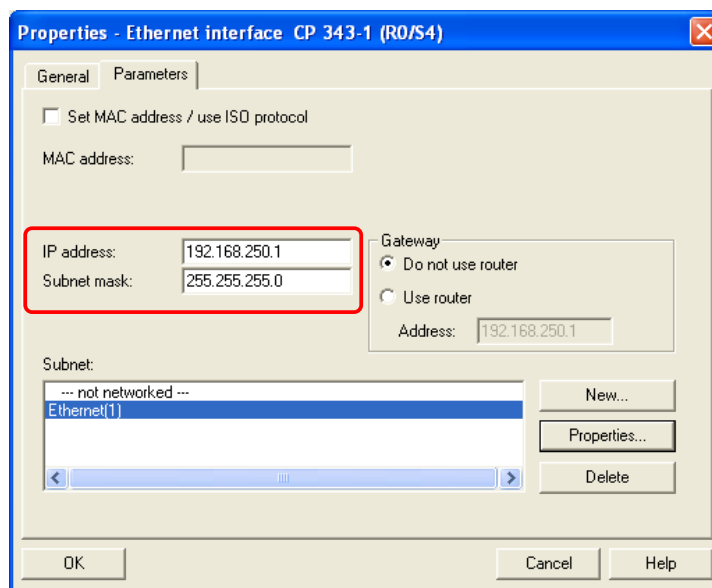

Communications cable

This is the connector used to connect the twisted-pair cable to the Ethernet.

- Electrical characteristics: Conforms to IEEE802.3 standards.
- Connector structure: RJ45 8-pin modular connector (conforms to ISO8877).

Sample Ladder Programming for Siemens PLC

This section provides an example of programming to monitor Safety Input terminal data of a G9SP-series Controller from a Siemens Standard PLC.

● Ethernet Communications Sequence

The G9SP-series Controller returns a response to the command sent from the Standard PLC.

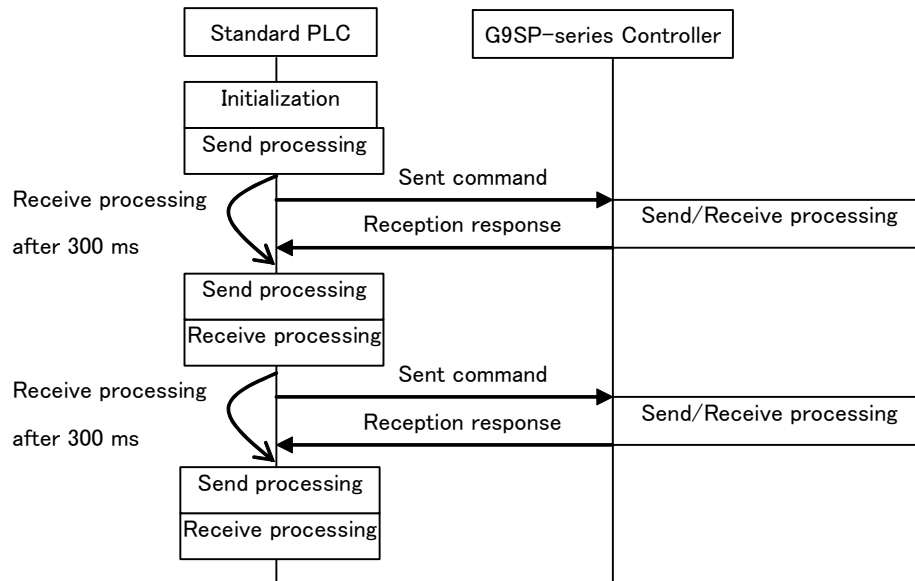

● Siemens PLC Memory Allocations

Start address	End address	Contents	Description
DB201.0	DB201.23	Ethernet send command	Data sent by the Standard PLC to the G9SP-series Controller
DB201.50	DB201.261	Ethernet reception response	Data received by the Standard PLC from the G9SP-series Controller
DB200.4.0	DB200.6.0	FC6 instruction control data	Control data for the FC6 instruction is stored.
DB200.4.0	DB200.6.0	FC5 instruction control data	Control data for the FC5 instruction is stored.
IW100	IW101	G9SP communications reception data (written to G9SP-series Controller)	Data written to G9SP-series Controller from Standard PLC. Stored in the communications reception data of the G9SP-series Controller. (Refer to Operation Manual 7-1-3 Transmission/Reception Data.)
QW100	QW101	G9SP communications transmission data (read from the G9SP-series Controller)	Communications data sent from the G9SP-series Controller is read. (Refer to Operation Manual 7-1-3 Transmission/Reception Data.)
QW102	QW104	G9SP Safety Input terminal data (read from the G9SP-series Controller)	Safety Input terminal data of the G9SP-series Controller is read. (Refer to Operation Manual 7-1-3 Transmission/Reception Data.)

- G9SP Communications Reception Data

	15								8								7								0														
IW100	bit	bit	bit	bit	bit	bit	bit	bit	bit	bit	bit	bit	bit	bit	bit	bit	bit	bit	bit	bit	bit	bit	bit	bit	bit	bit	bit	bit	bit	bit	bit	bit	bit	bit	bit	bit	bit	bit	bit
	15	14	13	12	11	10	09	08	07	06	05	04	03	02	01	00					31	30	29	28	27	26	25	24	23	22	21	20	19	18	17	16			
IW101	bit	bit	bit	bit	bit	bit	bit	bit	bit	bit	bit	bit	bit	bit	bit	bit	bit	bit	bit	bit	bit	bit	bit	bit	bit	bit	bit	bit	bit	bit	bit	bit	bit	bit	bit	bit	bit	bit	bit
	31	30	29	28	27	26	25	24	23	22	21	20	19	18	17	16																							

- G9SP Communications Transmission Data

	15								8								7								0													
QW100	bit	bit	bit	bit	bit	bit	bit	bit	bit	bit	bit	bit	bit	bit	bit	bit	bit	bit	bit	bit	bit	bit	bit	bit	bit	bit	bit	bit	bit	bit	bit	bit	bit	bit	bit	bit	bit	bit
	15	14	13	12	11	10	09	08	07	06	05	04	03	02	01	00					31	30	29	28	27	26	25	24	23	22	21	20	19	18	17	16		
QW101	bit	bit	bit	bit	bit	bit	bit	bit	bit	bit	bit	bit	bit	bit	bit	bit	bit	bit	bit	bit	bit	bit	bit	bit	bit	bit	bit	bit	bit	bit	bit	bit	bit	bit	bit	bit	bit	bit
	31	30	29	28	27	26	25	24	23	22	21	20	19	18	17	16																						

- G9SP Safety Input Terminal Data

	15								8								7								0													
QW102	Si	Si	Si	Si	Si	Si	Si	Si	Si	Si	Si	Si	Si	Si	Si	Si	Si	Si	Si	Si	Si	Si	Si	Si	Si	Si	Si	Si	Si	Si	Si	Si	Si	Si	Si	Si	Si	Si
	15	14	13	12	11	10	09	08	07	06	05	04	03	02	01	00																						
QW103	Reserved												Si	Si	Si	Si																						
																				19	18	17	16															
QW104	Reserved																																					

● Sample Ladder Programming

- DB200 Settings

	Address	Declaratio	Name	Type	Initial value	Actual value	Commen
1	0.0	in	IN0	BOOL	FALSE	TRUE	
2	2.0	stat	STAT1	BOOL	FALSE	FALSE	
3	2.1	stat	STAT2	BOOL	FALSE	FALSE	
4	2.2	stat	STAT3	BOOL	FALSE	TRUE	
5	2.3	stat	STAT4	BOOL	FALSE	FALSE	
6	2.4	stat	STAT5	BOOL	FALSE	FALSE	
7	2.5	stat	STAT6	BOOL	FALSE	FALSE	
8	2.6	stat	STAT7	BOOL	FALSE	FALSE	
9	2.7	stat	STAT8	BOOL	FALSE	TRUE	
10	4.0	stat	STAT9	INT	0	8	
11	6.0	stat	STAT10	WORD	W#16#0	W#16#100	
12	8.0	stat	STAT11	WORD	W#16#0	W#16#8181	
13	10.0	stat	STAT12	INT	0	-32381	
14	12.0	stat	STAT13	WORD	W#16#0	W#16#8180	
15	14.0	stat	STAT14	INT	0	-32381	
16	16.0	stat	STAT15	INT	0	0	
17	18.0	stat	STAT16	INT	0	0	
18	20.0	stat	STAT17	WORD	W#16#0	W#16#1100	
19	22.0	stat	STAT18.STAT19	BOOL	FALSE	TRUE	
20	24.0	stat	STAT18.STAT20	INT	0	0	
21	26.0	stat	STAT18.STAT21	INT	0	0	
22	28.0	stat	STAT18.STAT22	INT	0	0	
23	30.0	stat	STAT18.STAT23	INT	0	0	
24	32.0	stat	STAT18.STAT24	INT	0	0	
25	34.0	stat	STAT18.STAT25	INT	0	0	
26	36.0	stat	STAT18.STAT26	INT	0	0	

- Initial Settings

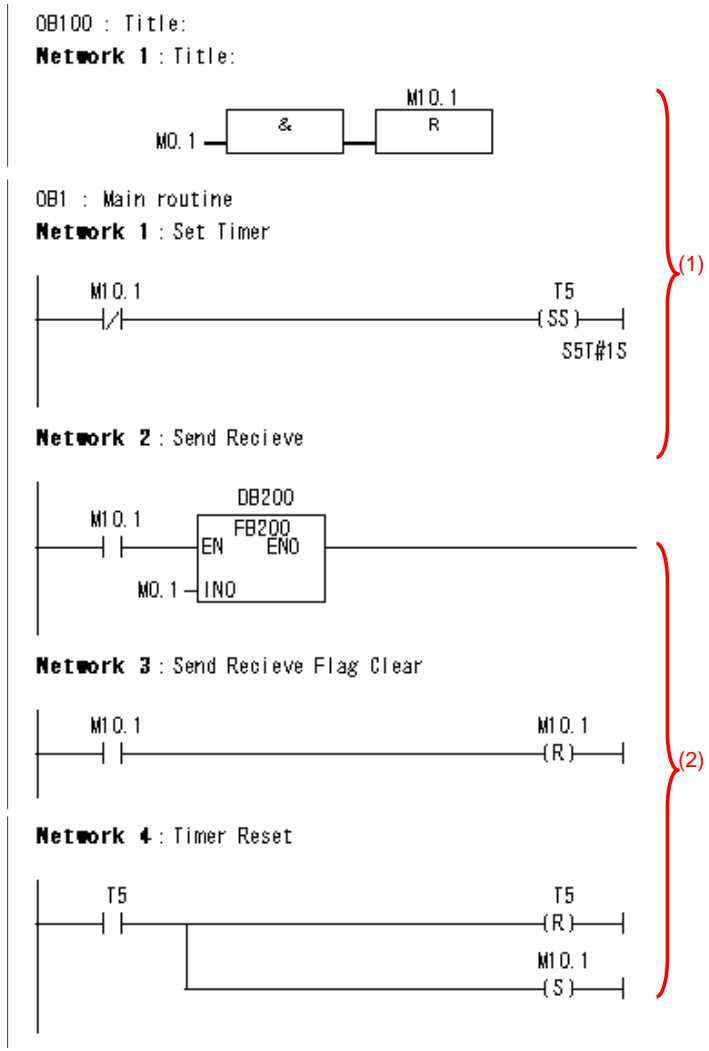

- Reception processing

FB200 : Title:

Network 1 : Title:

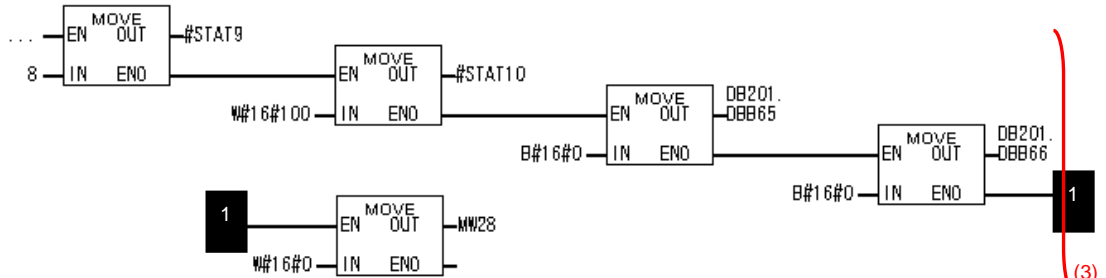

Network

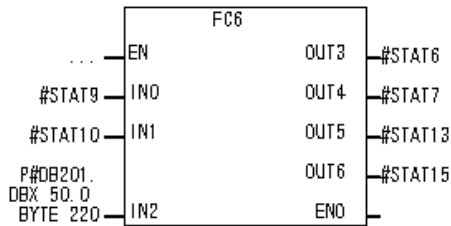

Network 3 : Title:

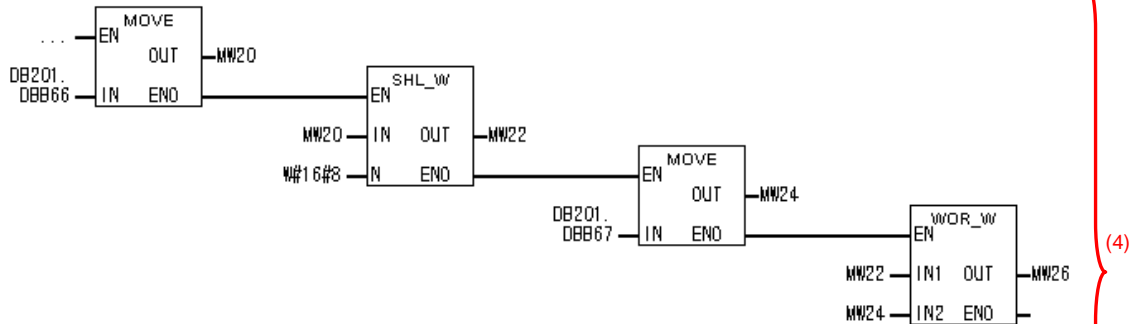

Network 4 : Title:

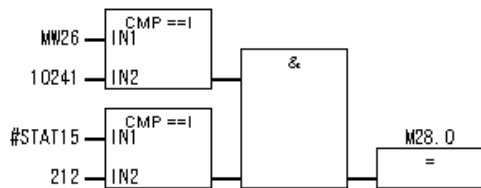

Network 5 : Title:

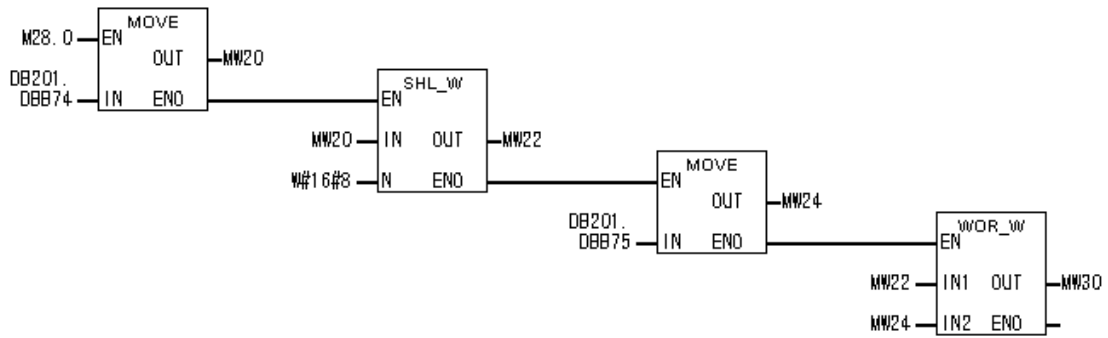

Network 6 : Title:

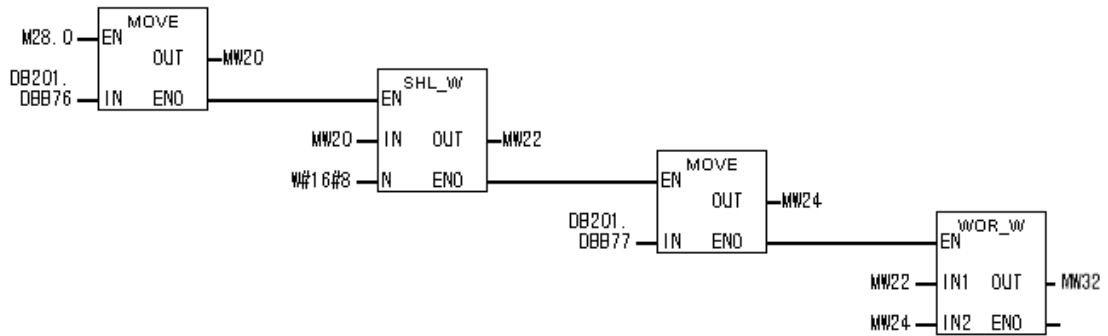

Network 7 : Title:

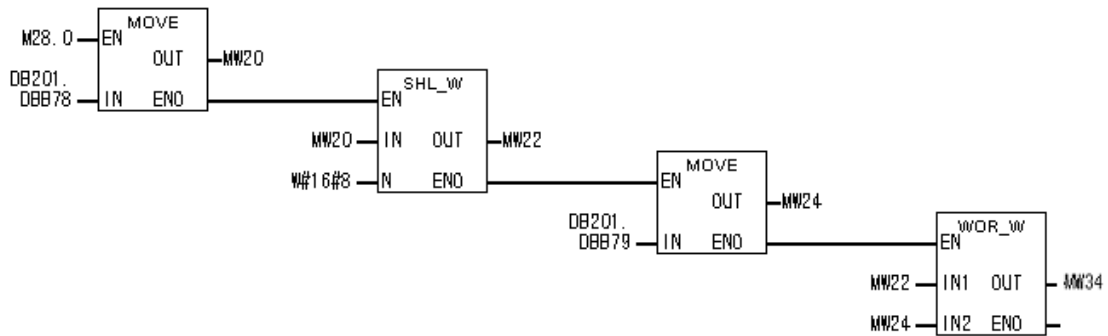

Network 8 : Title:

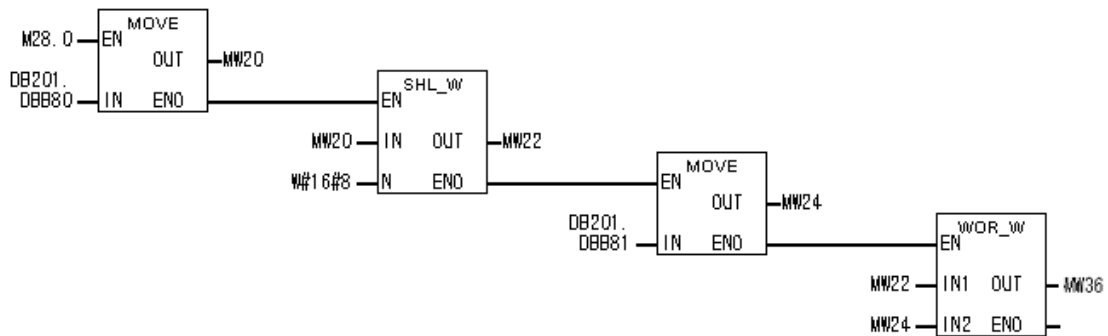

(5)

Network 9 : Title:

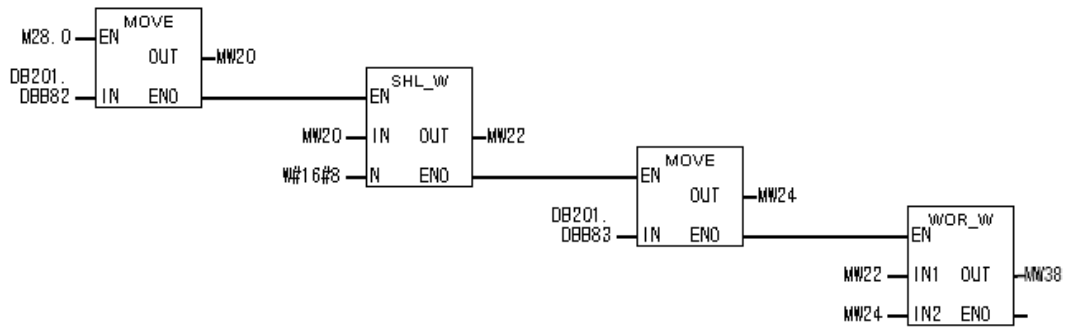

(5)

Network 10 : Title:

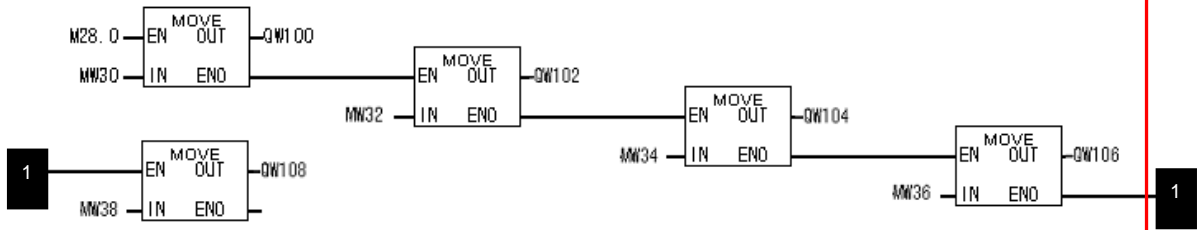

- Send processing

Network 11: Title:

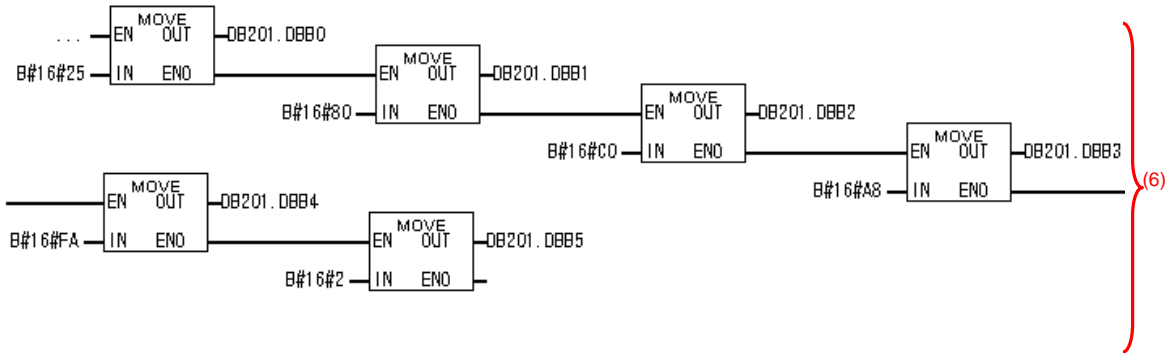

Network 12: Title:

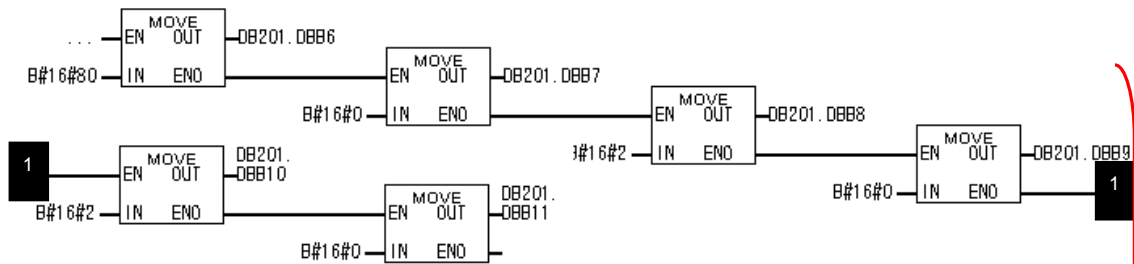

Network 13: Title:

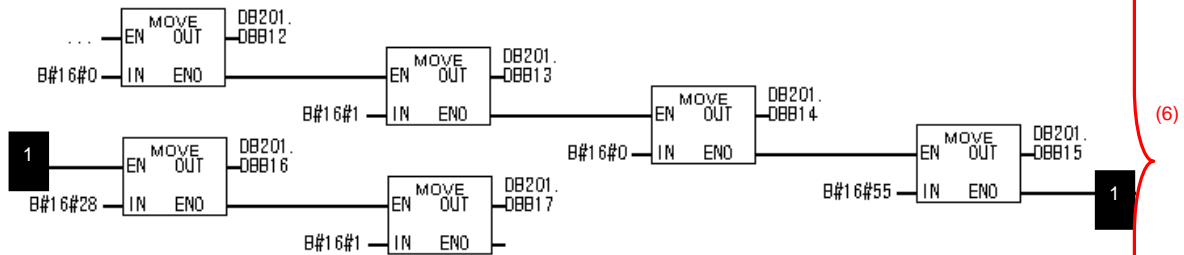

Network 14: Title:

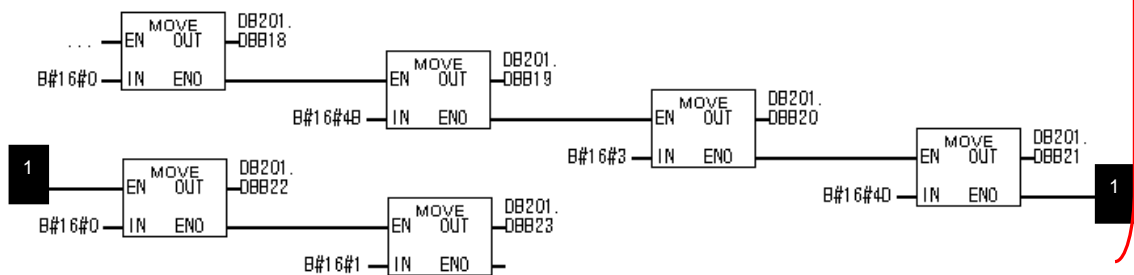

Network 15 : Title:

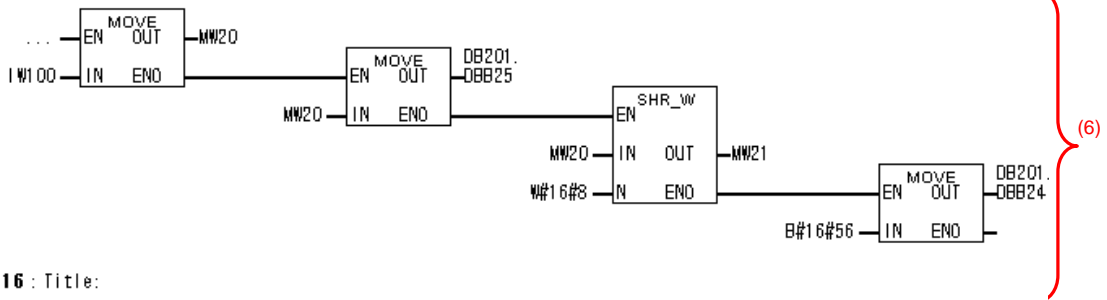

Network 16 : Title:

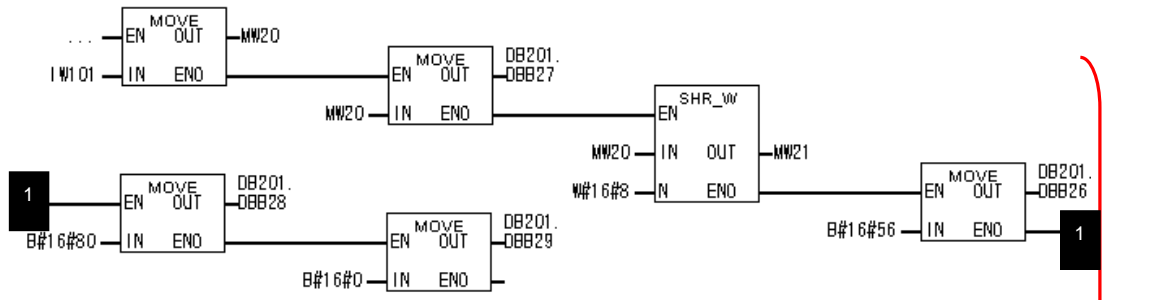

Network 17 : Title:

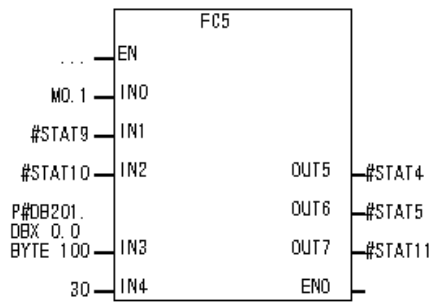

Step	Description
(1)	A communications refresh timer of 300 ms is started. This performs the first sending after 300 ms.
(2)	Once 300 ms has elapsed, send and receive processing is performed and the timer is restarted and the next send and receive processing is performed after 300 ms
(3)	Clear the receive area in preparation for the FC6 instruction. The reception size (#STAT15) is checked, and receive processing is performed if data has been received. A send command from the Standard PLC is initially required, and so reception processing is performed after completing the first send.
(4)	Once the data has been stored in the cleared receive area, check the size, and then start receive processing.
(5)	Copy G9SP Communications Transmission Data to QW 100 and QW 101 and G9SP Safety Input Terminal Data to QW 102 to QW 104.
(6)	The fixed portion of the send command is set.
(7)	Once receive processing has been completed, set G9SP Communications Reception Data to the send command from IW 100. The send command is sent to the Ethernet send port, which enables sending to the G9SP-series Controller.